

September 2009 • Matthew Burger



design dialogue:

September 2009 • Matthew Burger

industrial design

... in future tense

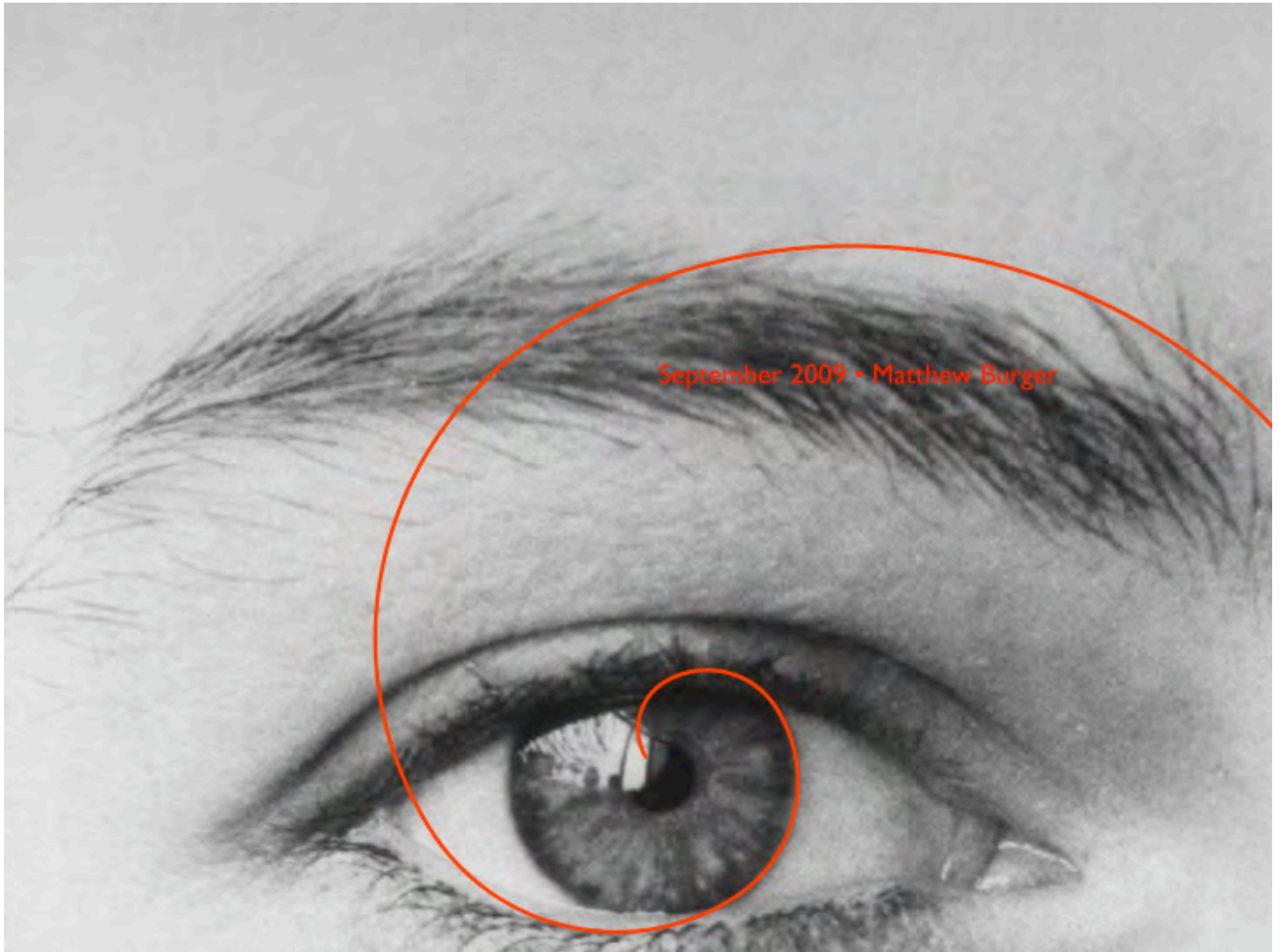

September 2009 • Matthew Burger

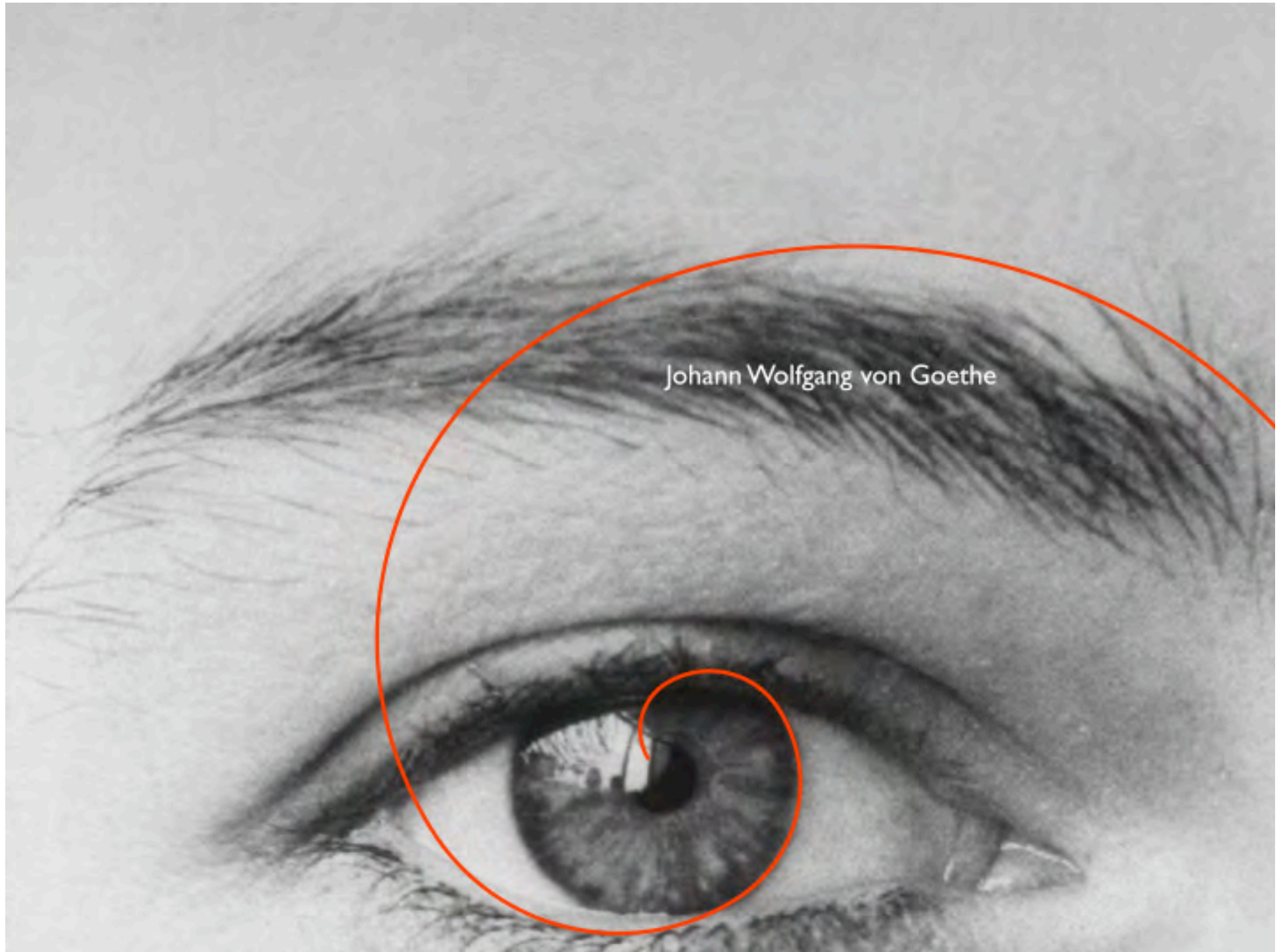

Johann Wolfgang von Goethe

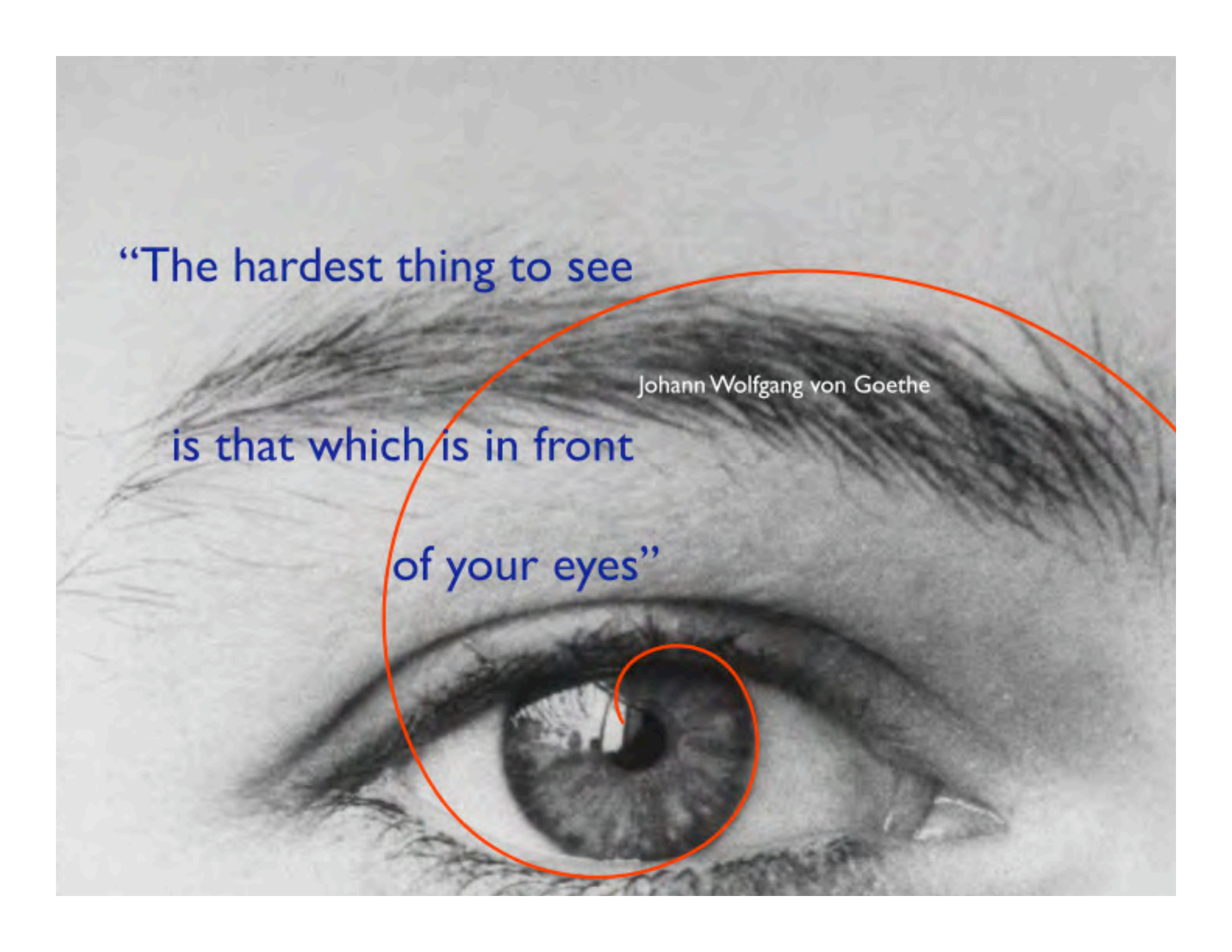

“The hardest thing to see

Johann Wolfgang von Goethe

is that which is in front

of your eyes”



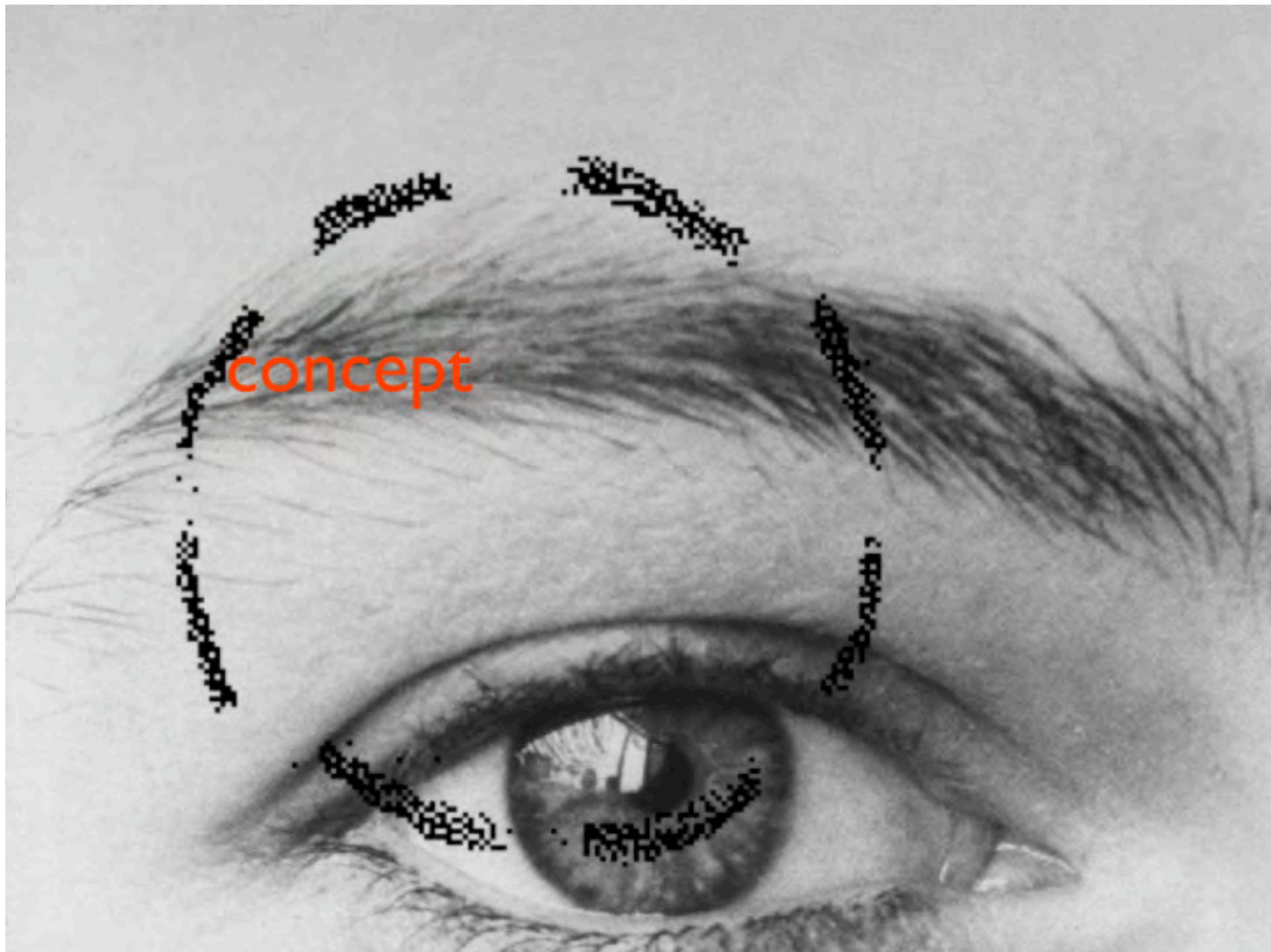

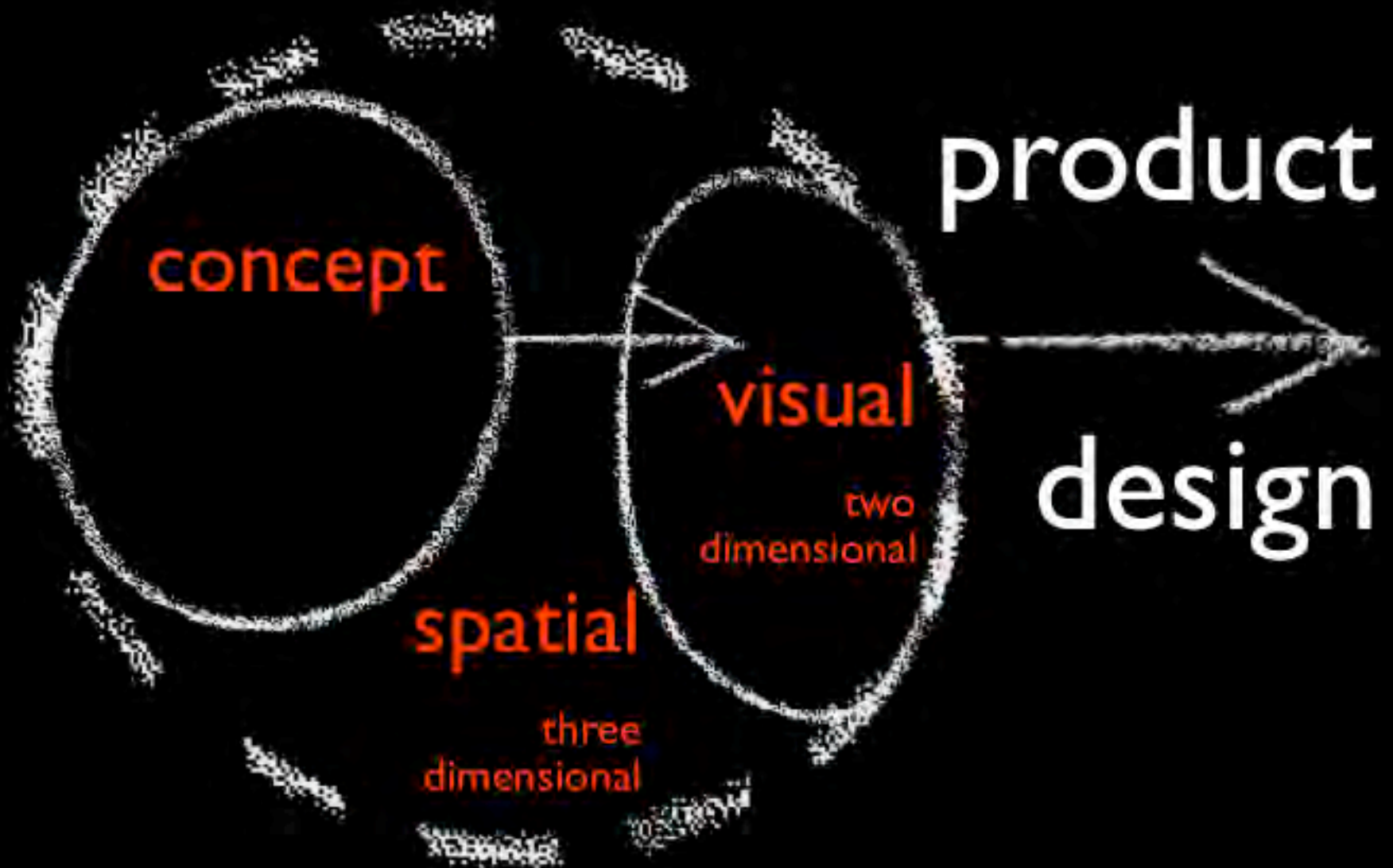

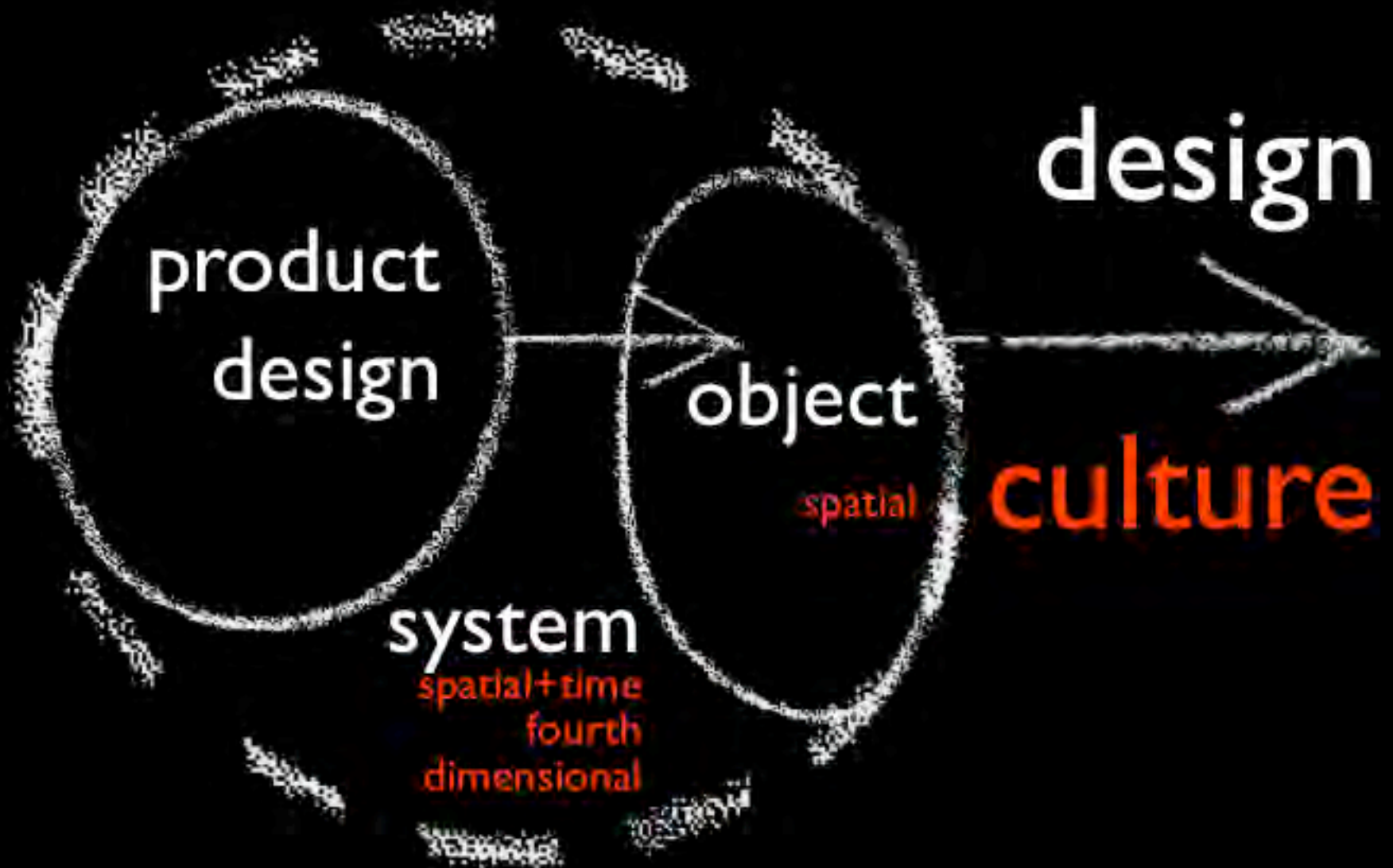

design

product

object

culture

system



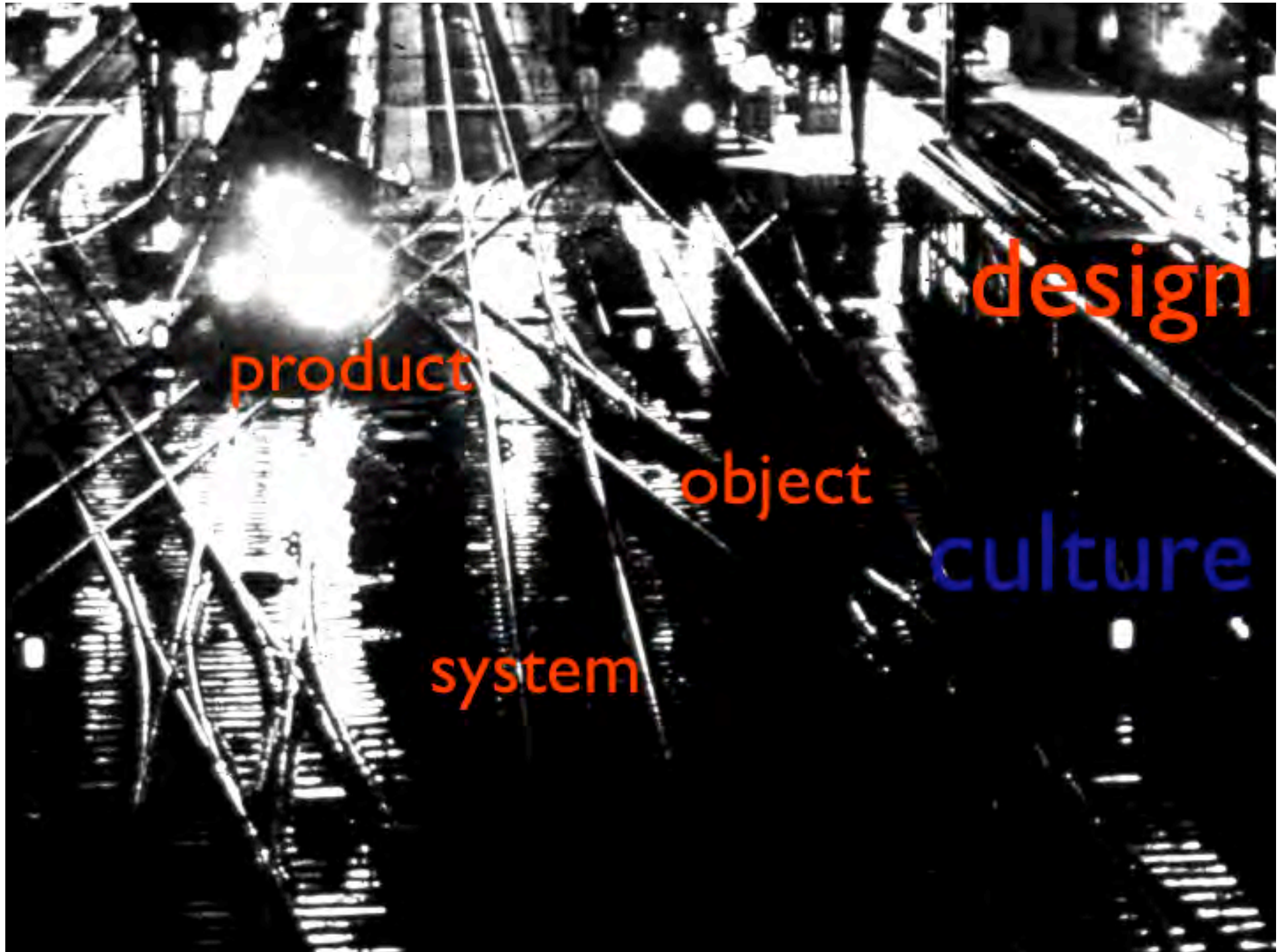

product

design

object

culture

system



swiss federal railways



swiss federal railways



swiss federal railways



swiss federal railways

2. Taste der Billetsorte drücken

→ = einfache Fahrt
⇄ = Hin- und Rückfahrt
1/2 = halber Preis

3. Münzen und/oder Noten eingeben

4. Billet und Rückgeld entnehmen

2. Appuyez sur la touche de la sorte de billet

→ = simple course
⇄ = aller et retour
1/2 = demi-prix

3. Introduisez les pièces de monnaie et/ou les billets de banque

4. Prenez le billet et la monnaie rendue

2. Premere il tasto della specie di biglietto desiderata

→ = corsa semplice
⇄ = andata e ritorno
1/2 = mezzo prezzo

3. Introdurre monete o banconote

4. Ritirare il biglietto e le monete di resto

2. Press button for type of ticket

→ = single
⇄ = return
1/2 = half fare

3. Insert coins and/or notes

4. Take ticket and change

Automat gibt Rückgeld
L'automate rend la monnaie

| | | | | |
|---|--|---------------------------------------|--|--|
| Aarberg <small>via Luzern</small> | Brugg SE | Nerzogenbuchsee | Luarn <small>via Bern-Langnau + Olten</small> | Schöpfen |
| Aarburg-Oftringen | Burgdorf | Nidebach | Lyss | Spiez |
| Basel SBB <small>via Bern-Luzern</small> | Inslerhof Steinhof | Interlaken Ost | Lyssach | Seborg <small>Grossschönen</small> |
| Basel | Busswil | Interlaken West | Metzstetten | Suskowald-Grünen |
| Bellinzona | Flamatt | Kandersteg | Münchenbuchsee | Thun |
| Bern-Bümpliz Nord | Fribourg | Kehrsatz | Münsingen | Zürich <small>via Bern nur Klasse 1. Klasse</small> |
| Bern-Bümpliz Süd | Göriswil <small>via Olten + Luzern</small> | Kirchberg <small>via Olten</small> | Neuchâtel <small>via Bern-Luzern</small> | Zürich Flughafen <small>via Bern nur Klasse 1. Klasse</small> |
| Bern-Säckingen | Grindelwald-Altgrindelwald <small>1. Klasse</small> | Lengnau | Oberburg | Rundfahrtsbillette |
| Biel/Bienne | Gündwil | Langnau <small>via Bern</small> | Olten | Zürcher SBB-Gare <small>Zürcher Hauptbahnhof oder Flughafen</small> |
| Basel <small>via Olten + Luzern</small> | Häfe-Riggenau | | | |

swiss federal railways

2. Klasse
2. classe

→

1/2 →

⇄

1. Klasse
1. classe

→

1/2 →

⇄

1/2 ⇄

20 Fr.
Banknote wie oben
einfühen
Introduire le billet de
comme indiqué sur



swiss federal railways



swiss federal railways



Brünig Panorama



Brünig Panorama

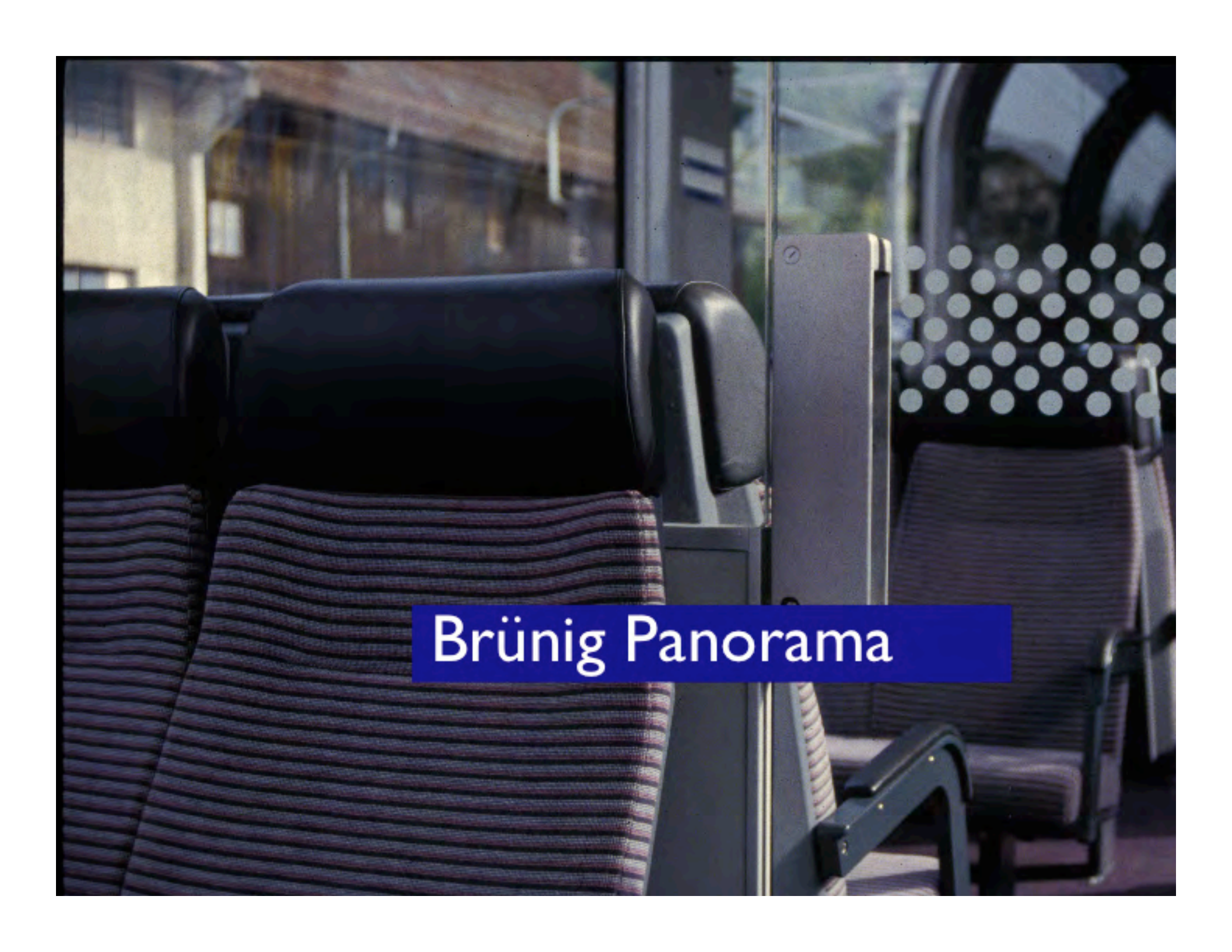

Brünig Panorama

The image shows the interior of a train car, likely a panoramic train. In the foreground, there are several rows of seats with dark, padded headrests and seats upholstered in a dark fabric with light-colored horizontal stripes. A vertical metal post is visible between the seats. In the background, a window with a decorative perforated metal screen is visible, and through it, a blurred view of a building and trees can be seen. The overall lighting is soft and natural.

Brünig Panorama



Brünig Panorama



Brünig Retro-fit



Brünig Retro-fit

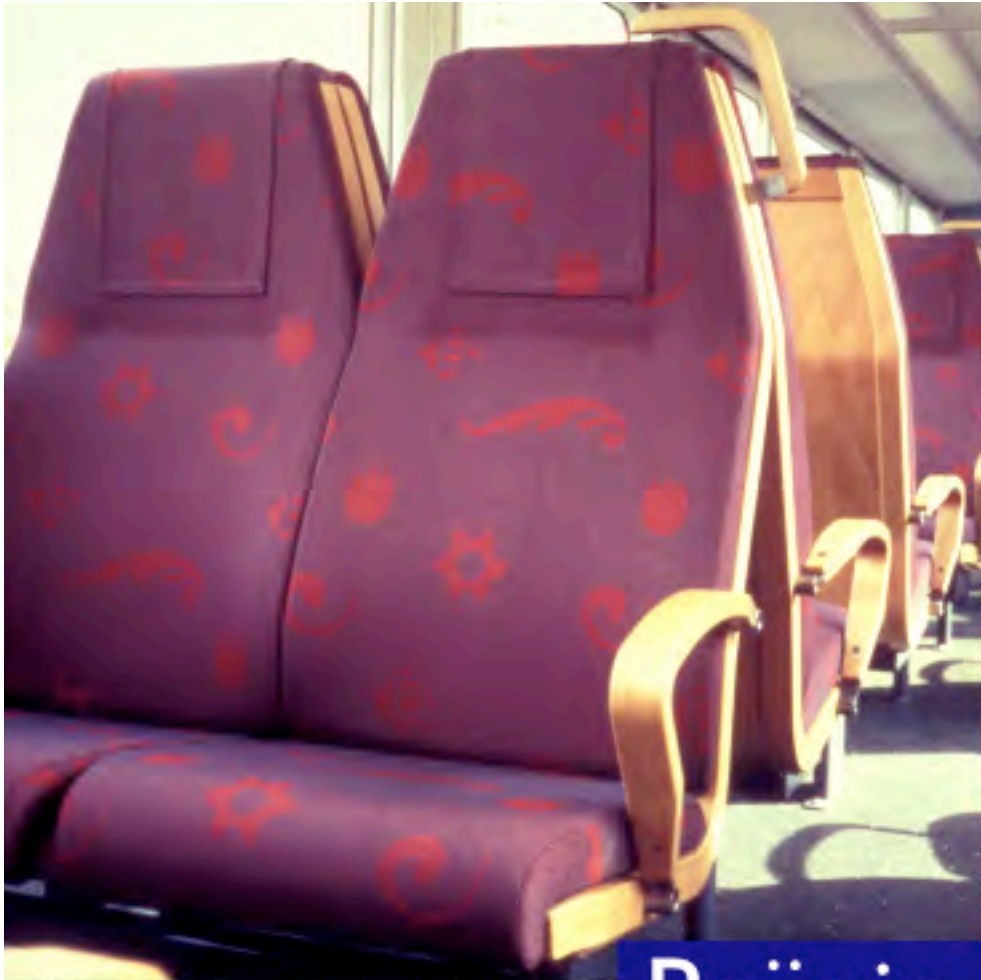

Brüning Retro-fit



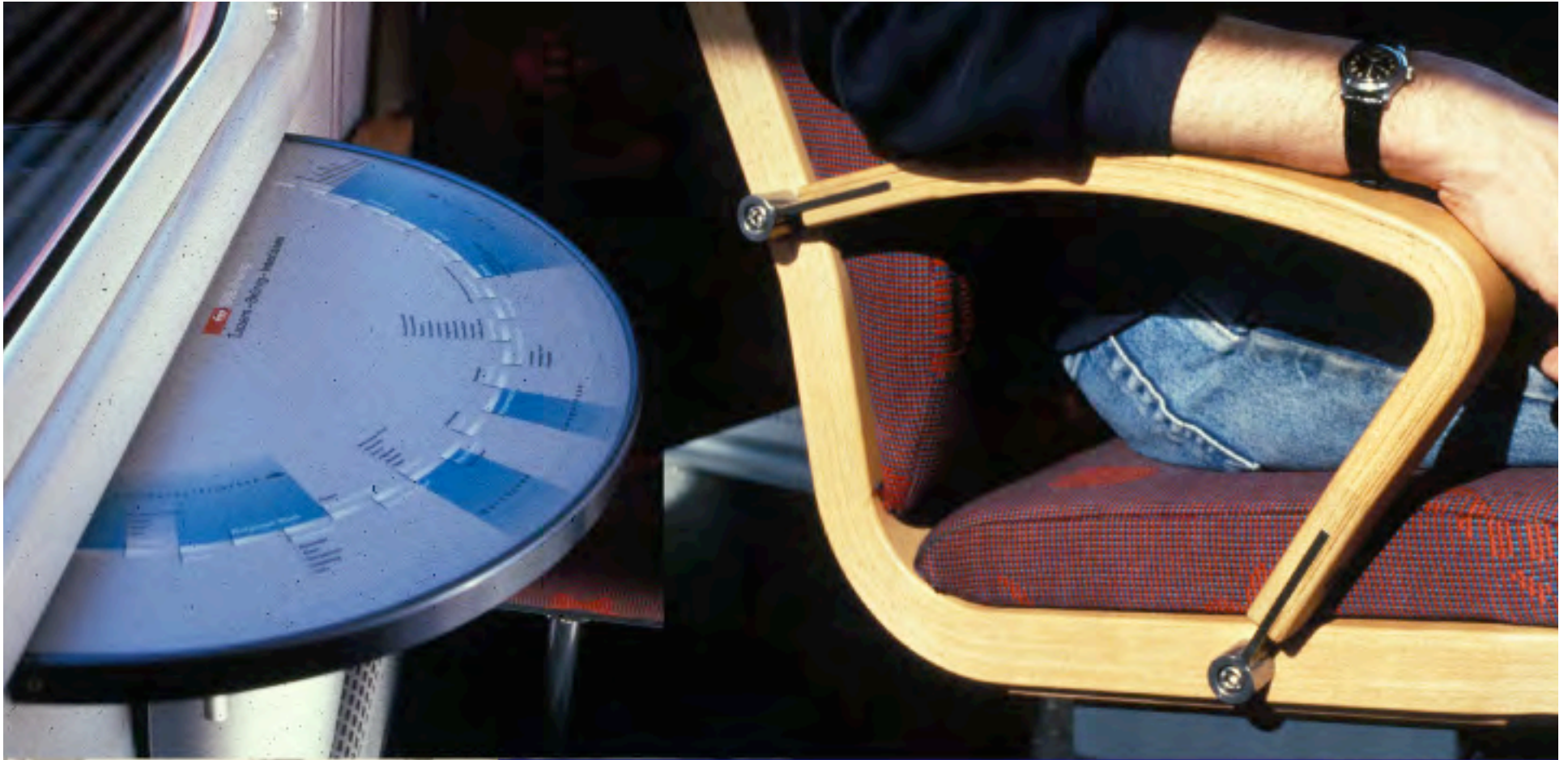

Brünig Retro-fit





Brünig SBB CFF FFS

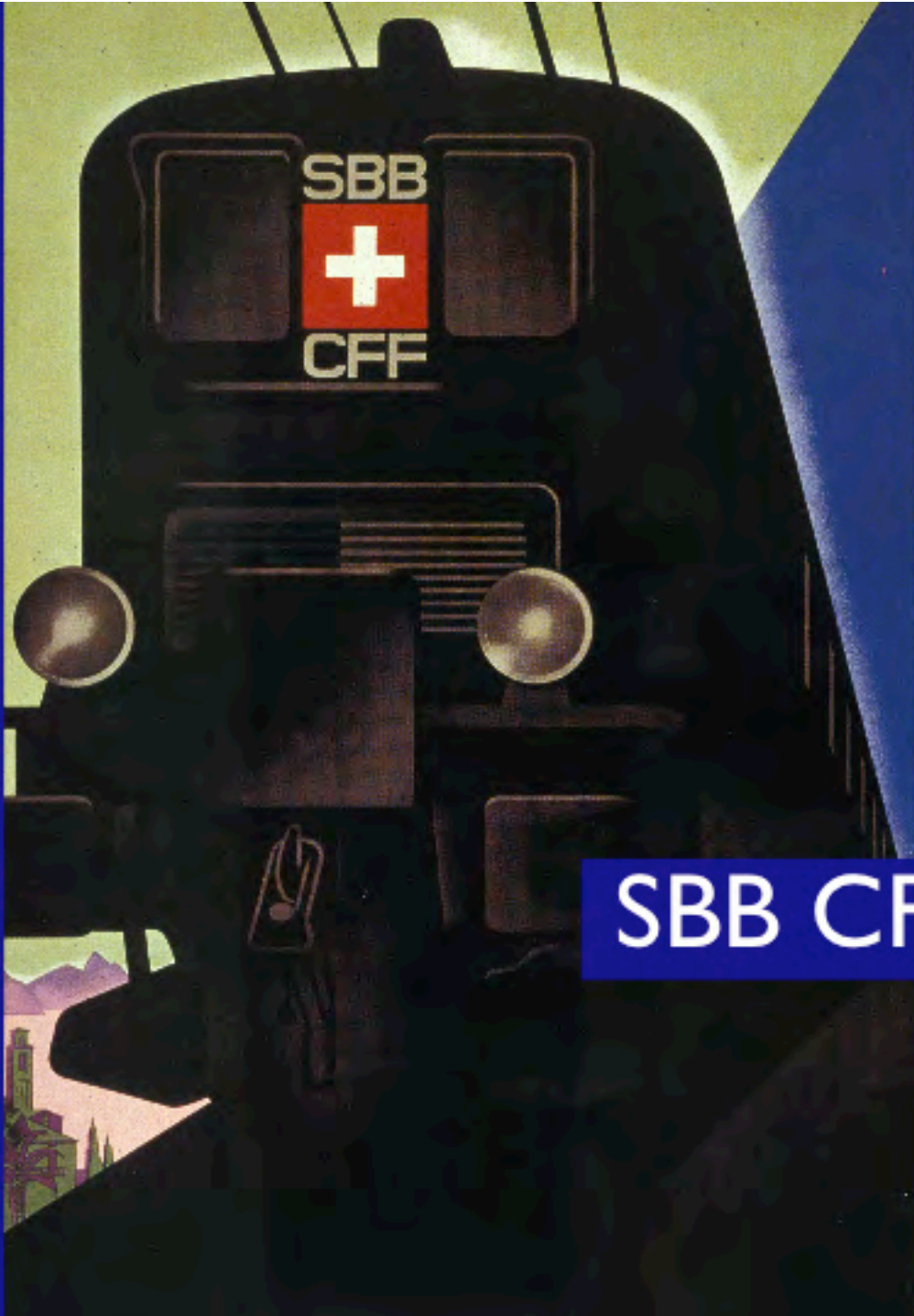

SBB CFF FFS

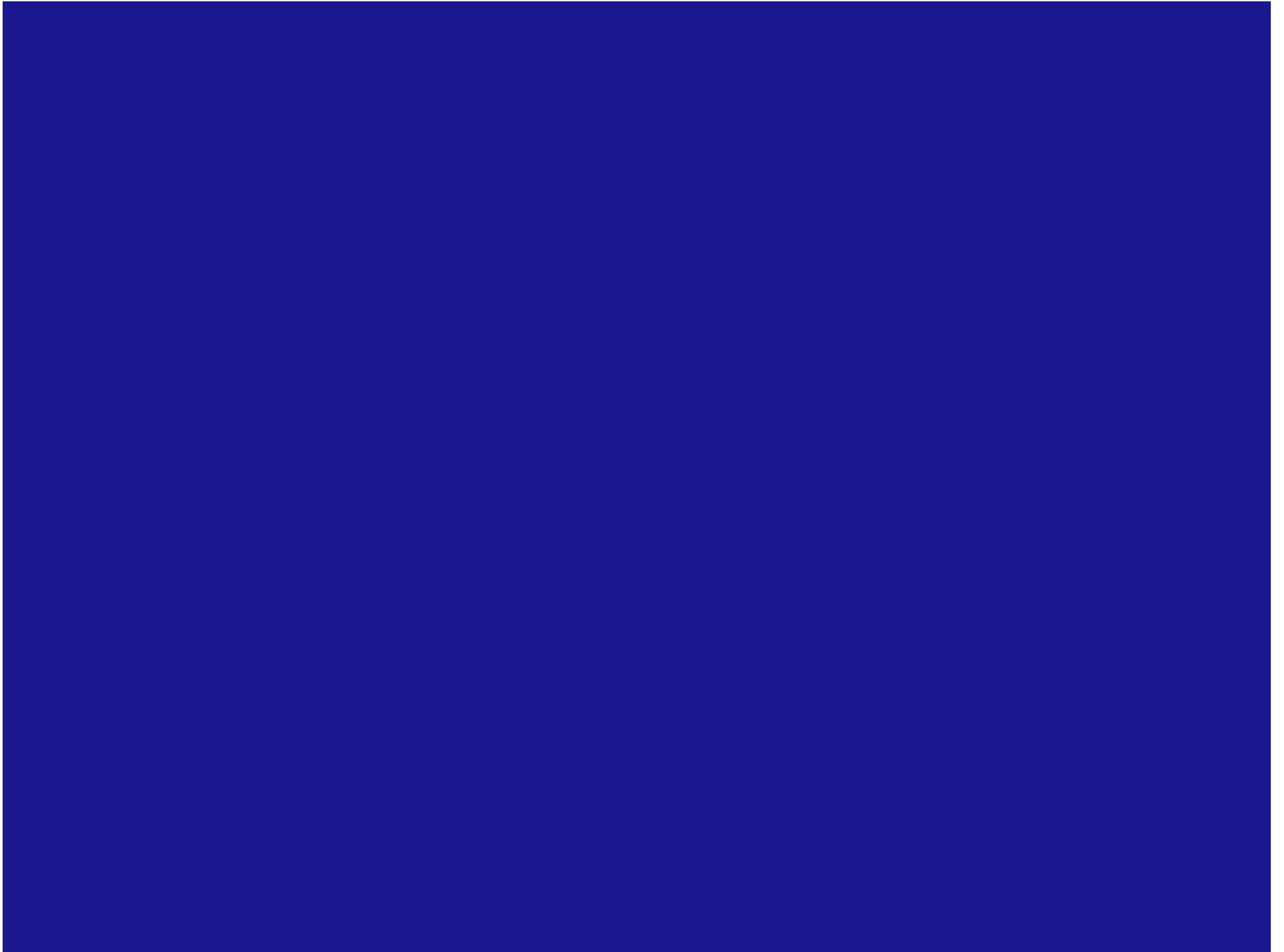



the basis for
a design dialogue:
Industrial Design at Pratt

... future tense



the basis for
a design dialogue:
from present to

... future tense



the basis for
a design dialogue:

... future tense

innovation

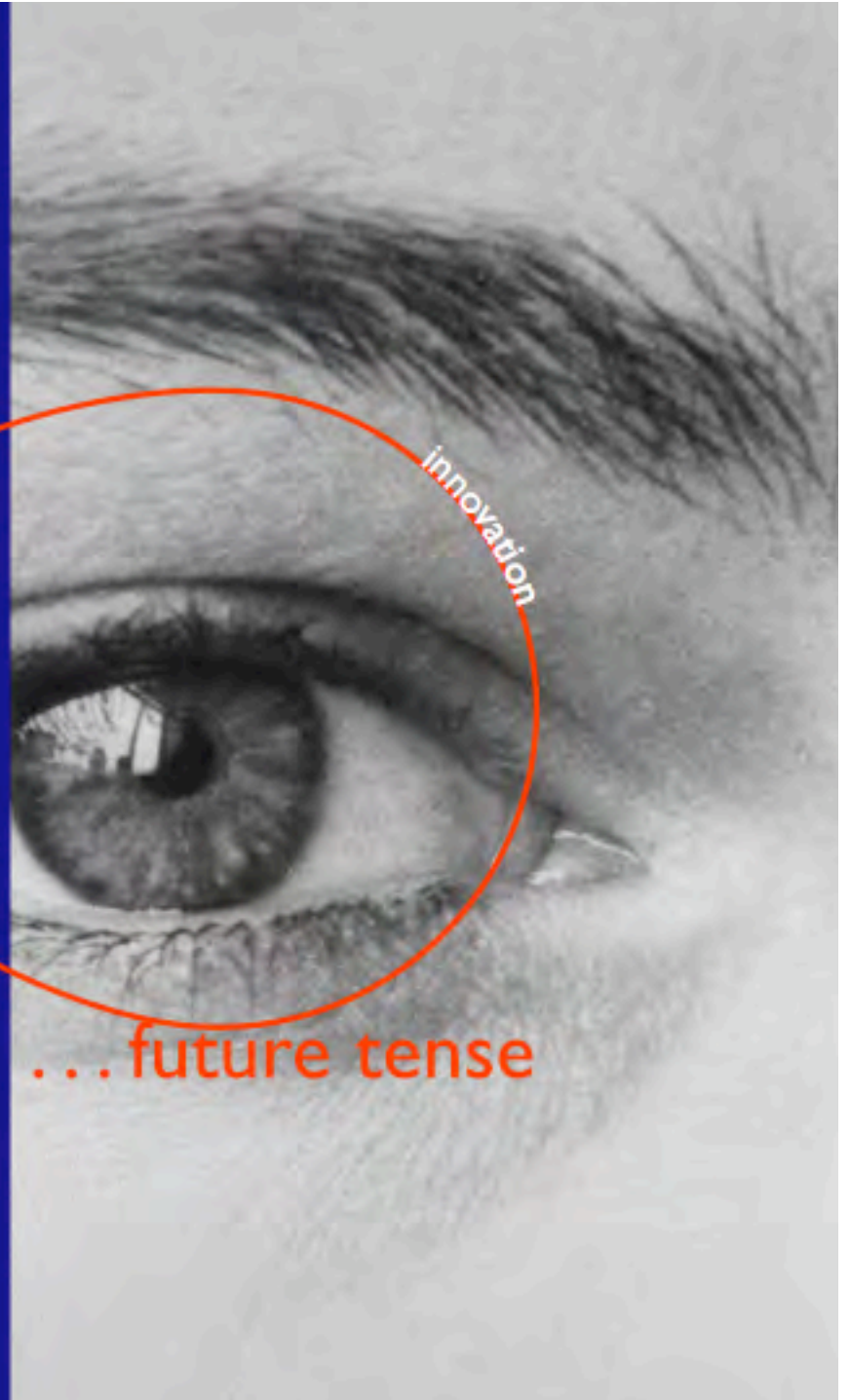

the basis for
a design dialogue:
innovation



a design dialogue:
economy



a design dialogue:
ecology

ecology

economy

innovation

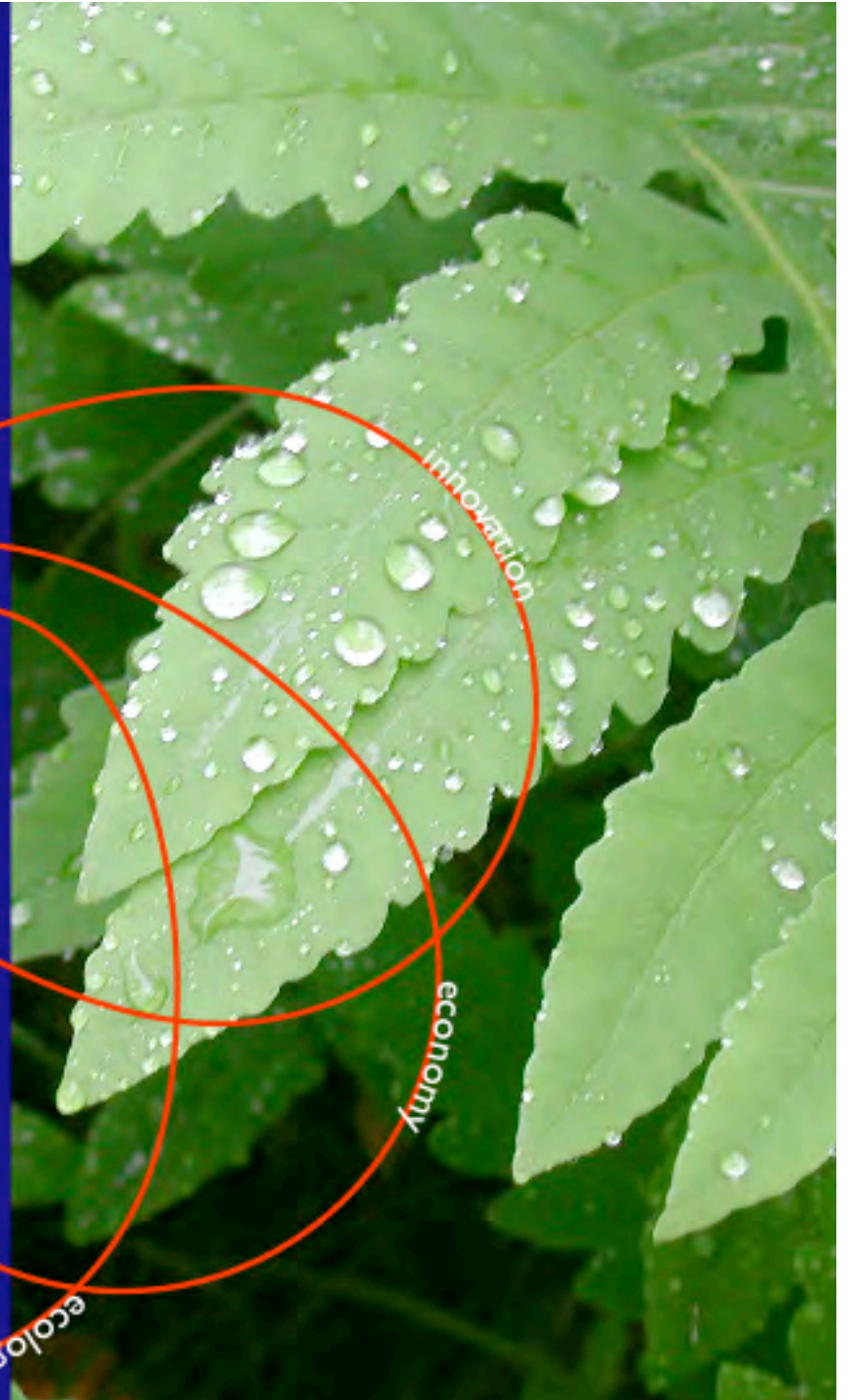

production process

a design dialogue:
production process

ecology



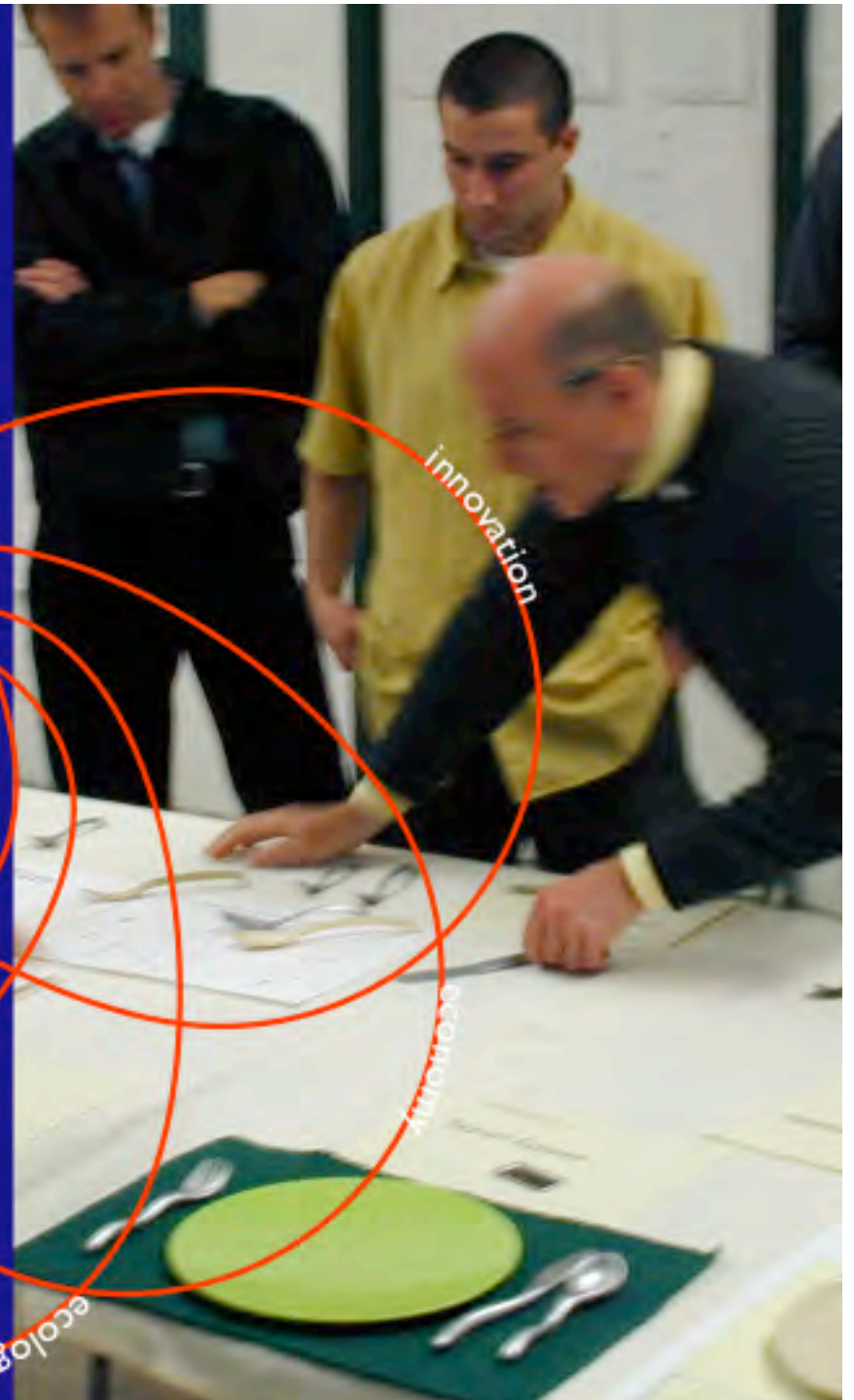
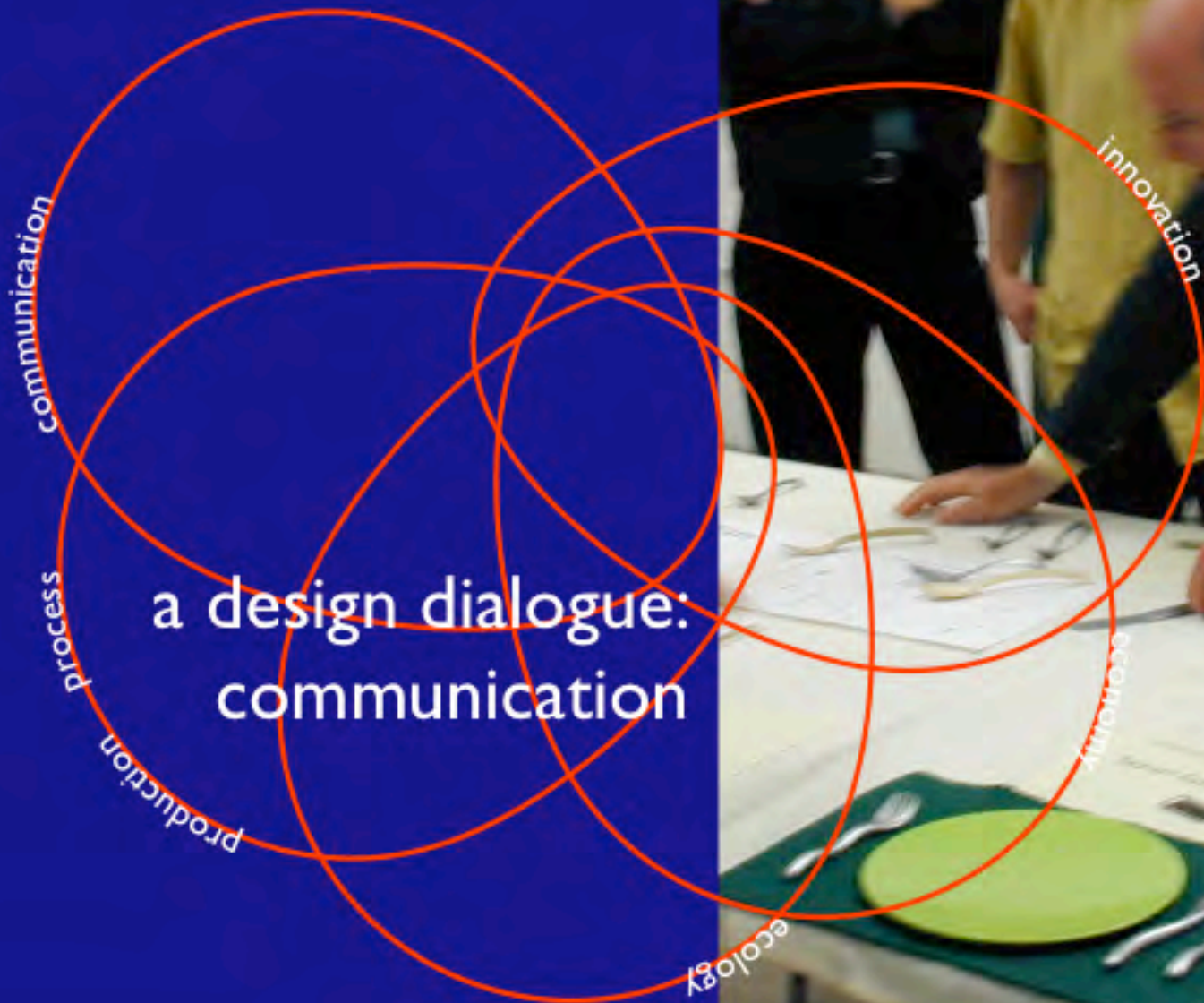

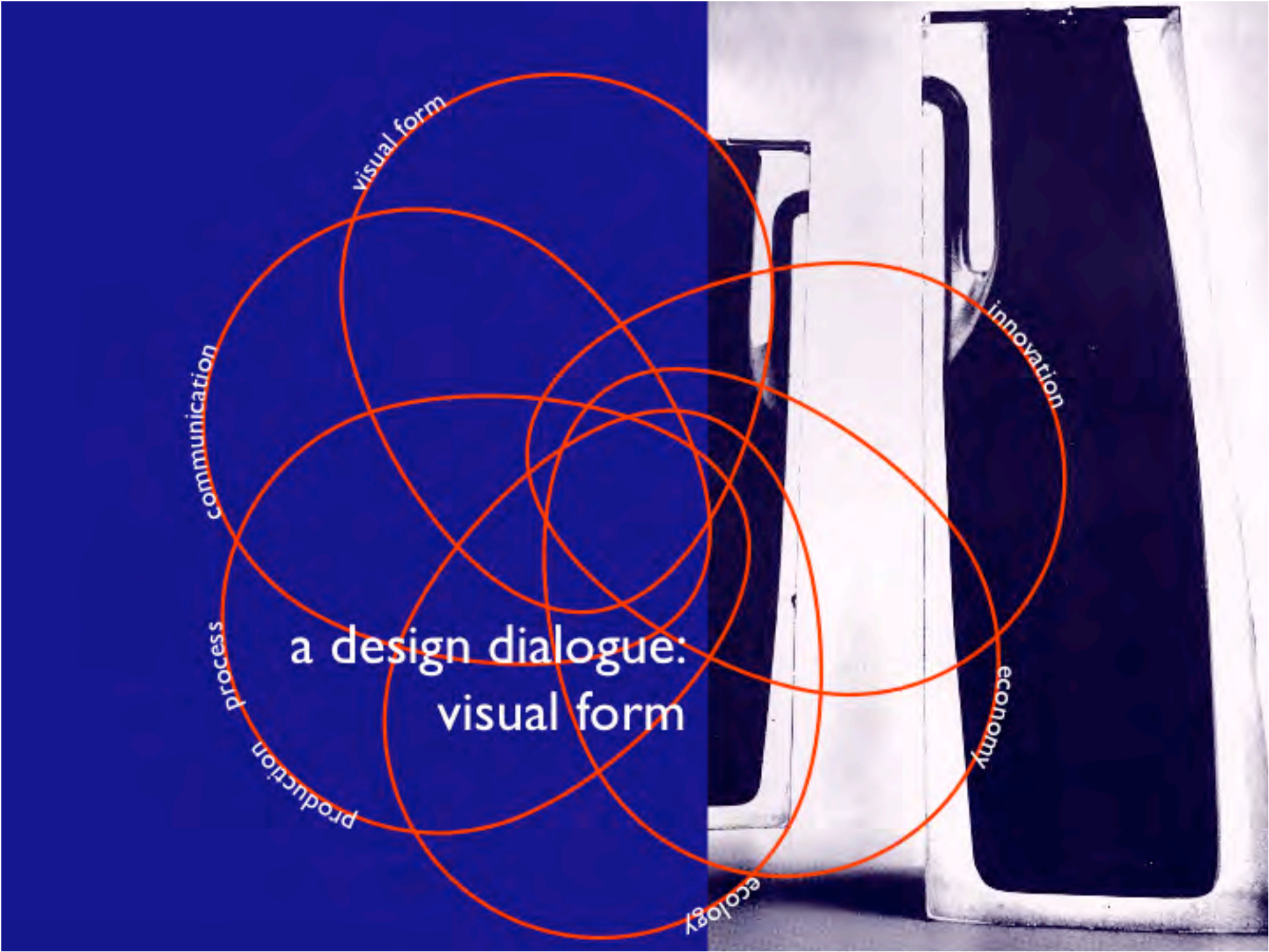

a design dialogue:
visual form

visual form

communication

process

production

ecology

economy

innovation



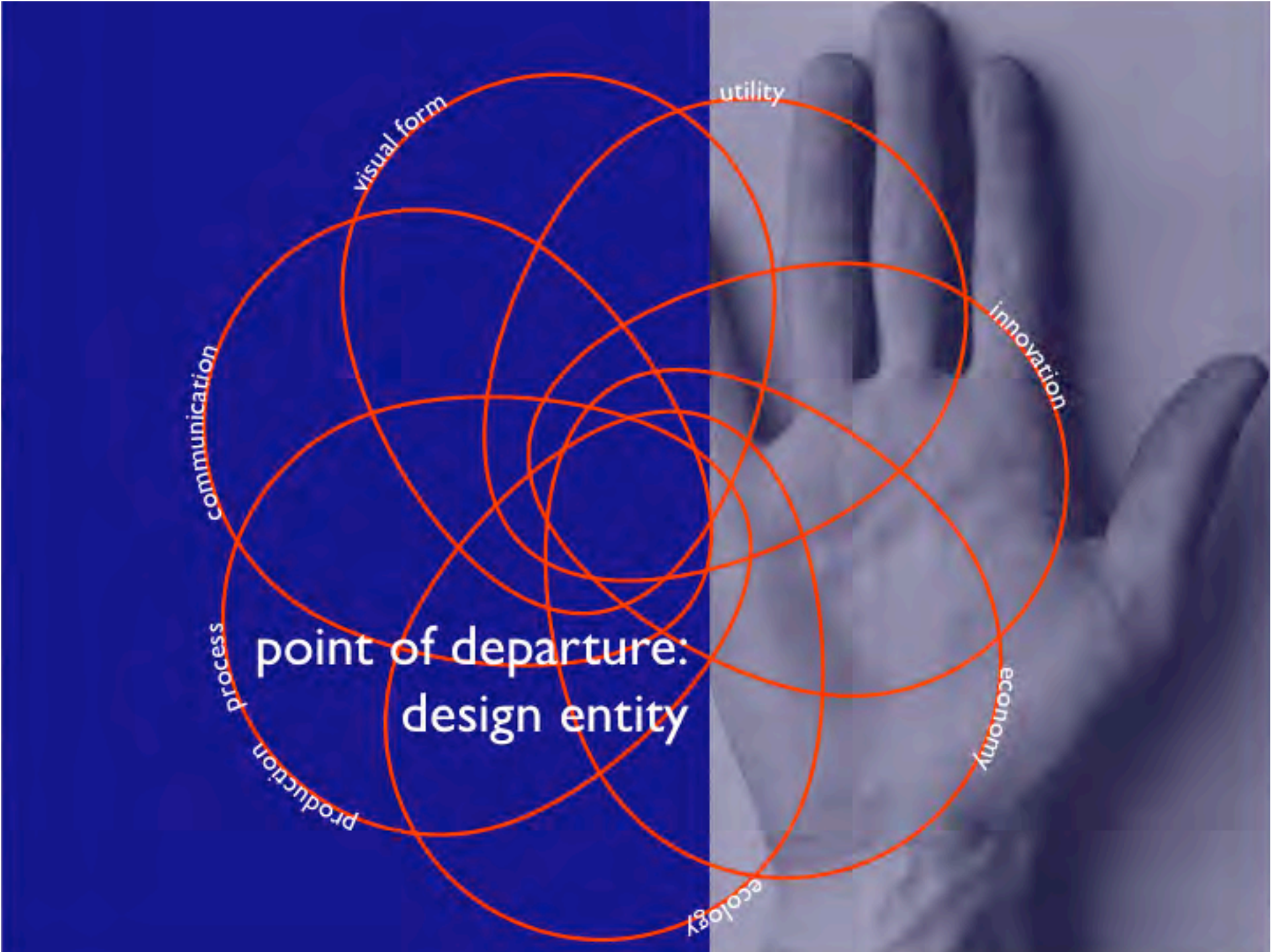

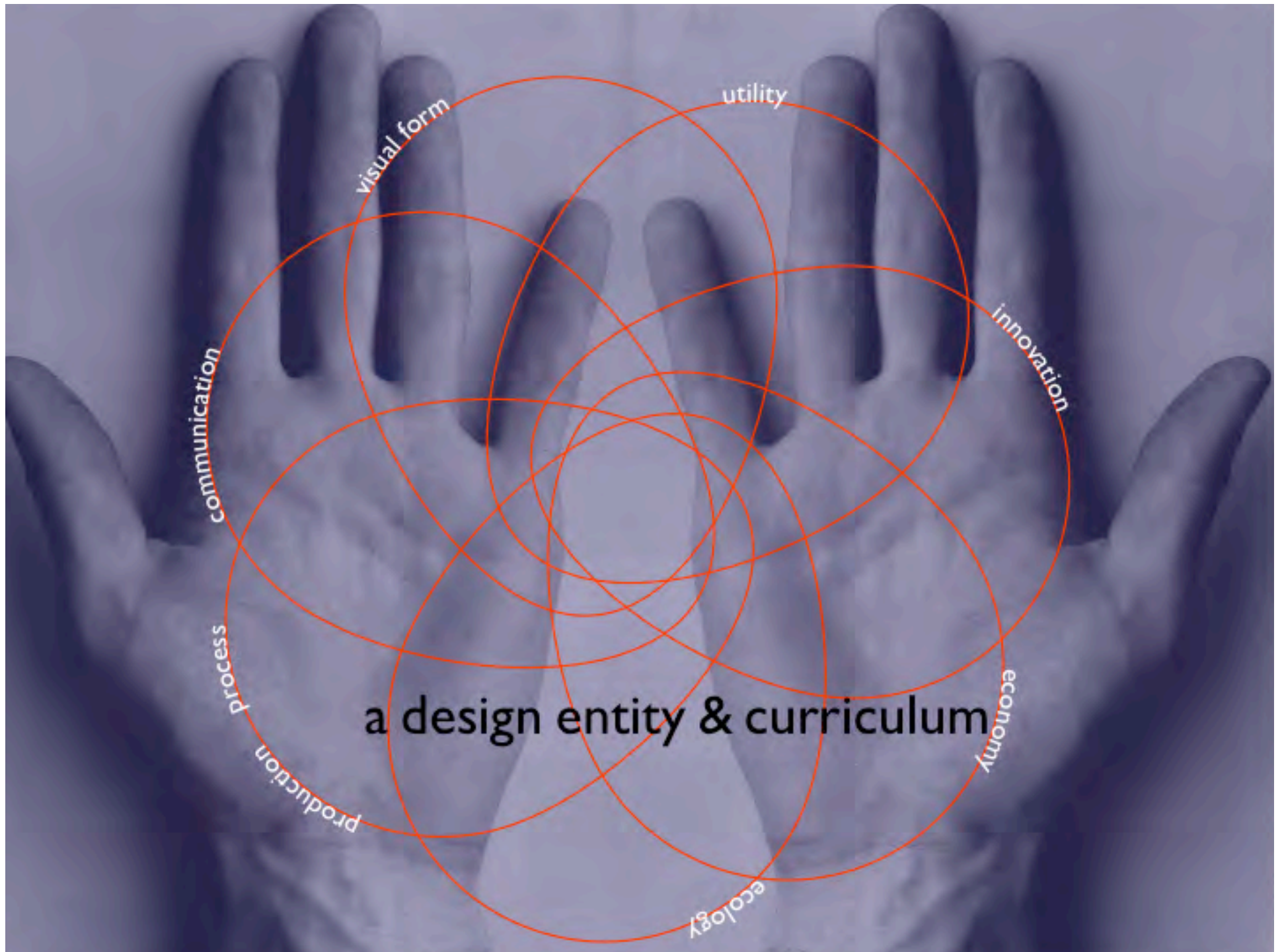

visual form

utility

innovation

communication

economy

process

production

ecology

a design entity & curriculum

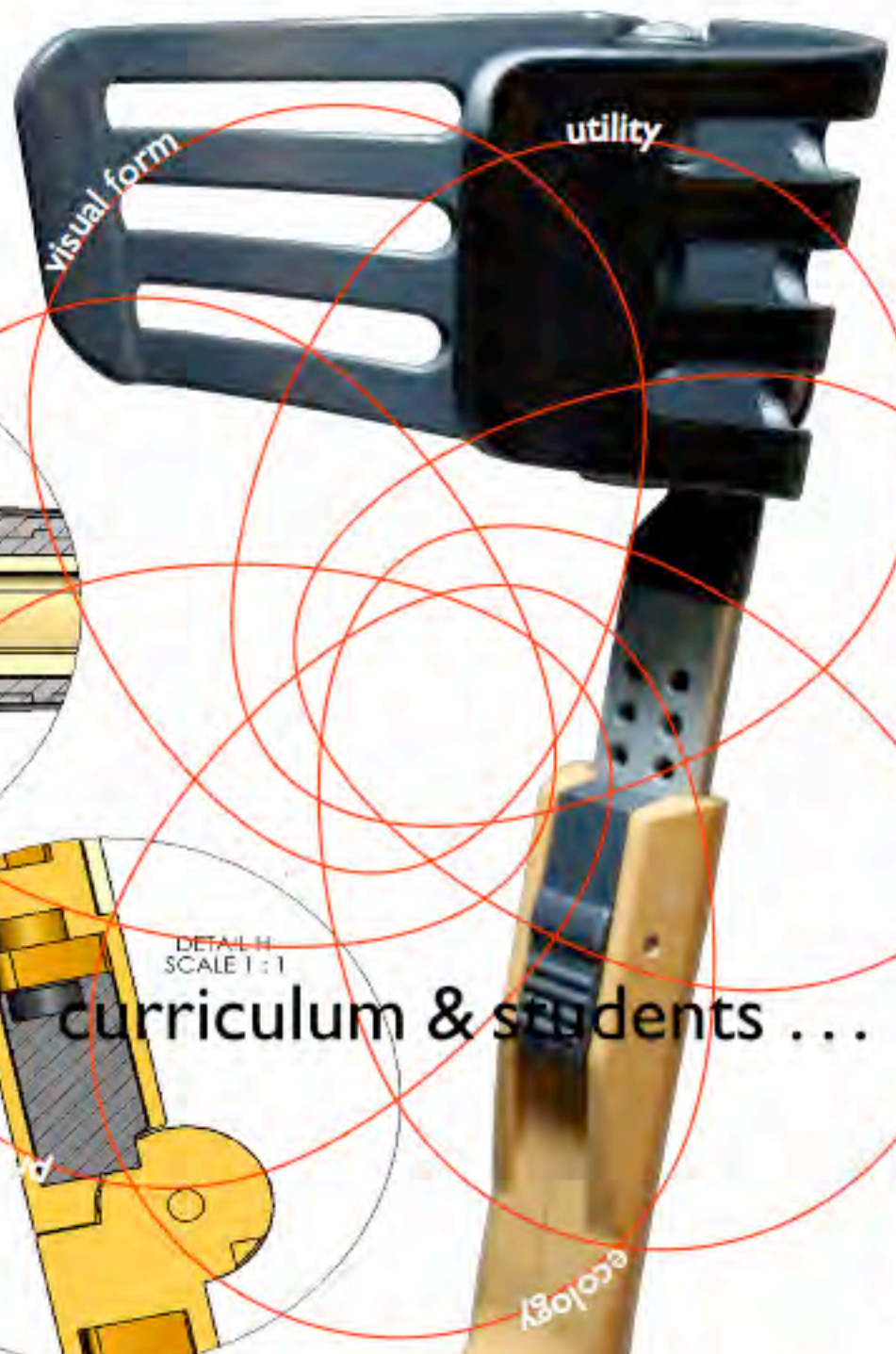

DETAIL K
SCALE 1:1

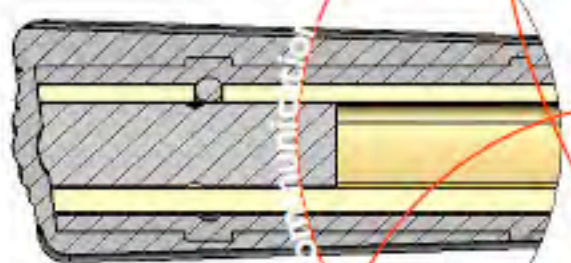

communication

DETAIL H
SCALE 1:1

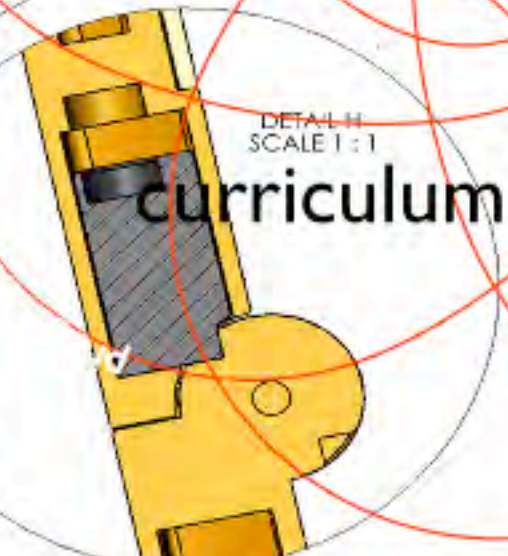

by

curriculum & students ...

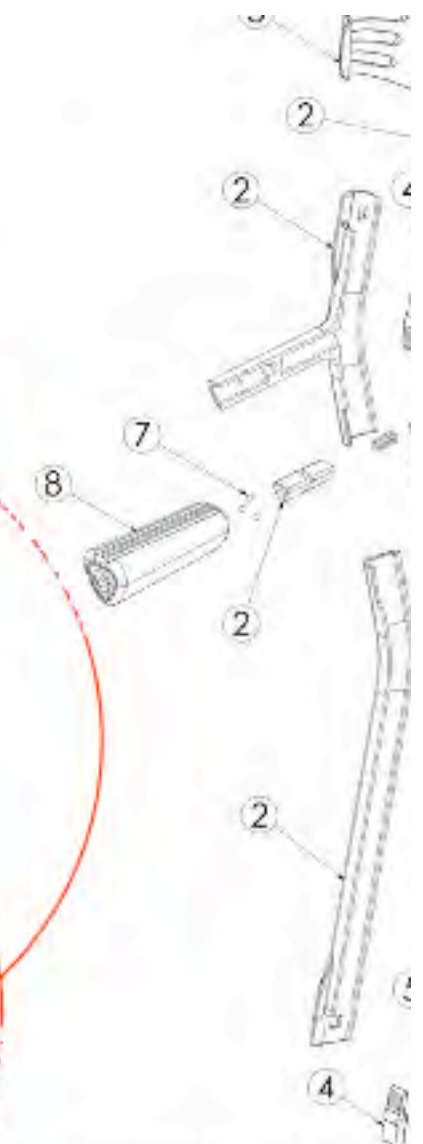

| | |
|---|-------------------------------|
| 1 | Stainless Steel |
| 2 | Nylon 6/10 with 15% glass |
| 3 | Low Density Polyethylene |
| 4 | Nylon & Cast Aluminum |
| 5 | Stainless Steel Pin |
| 6 | Extruded & Machined Aluminum |
| 7 | Stainless Steel Ball Bearings |
| 8 | polychloroprene (Neoprene) |

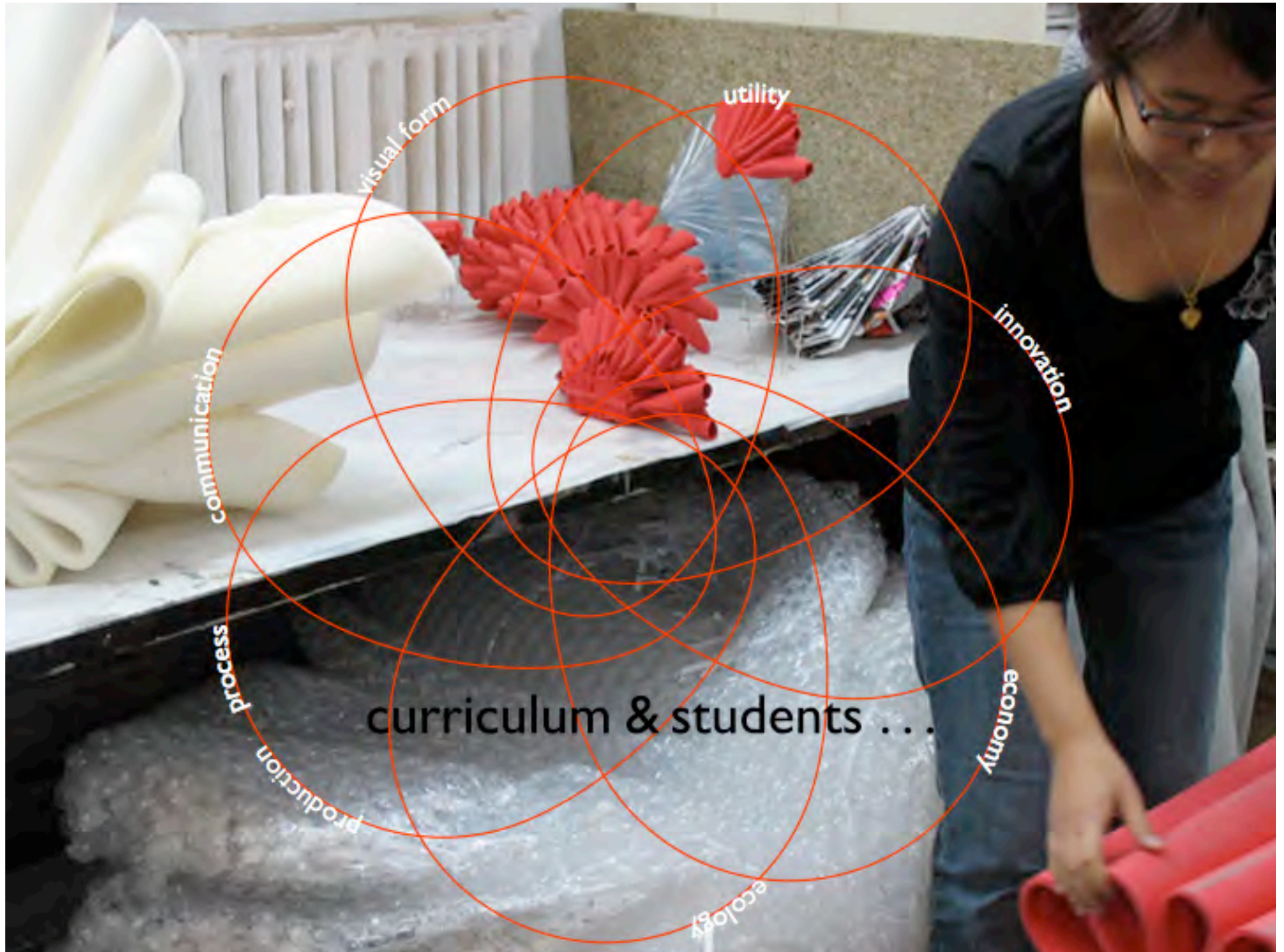

visual form

utility

innovation

communication

process

production

economy

ecology

curriculum & students ...



visual form

utility

communication

innovation

process

students with each other

economy

production

ecology

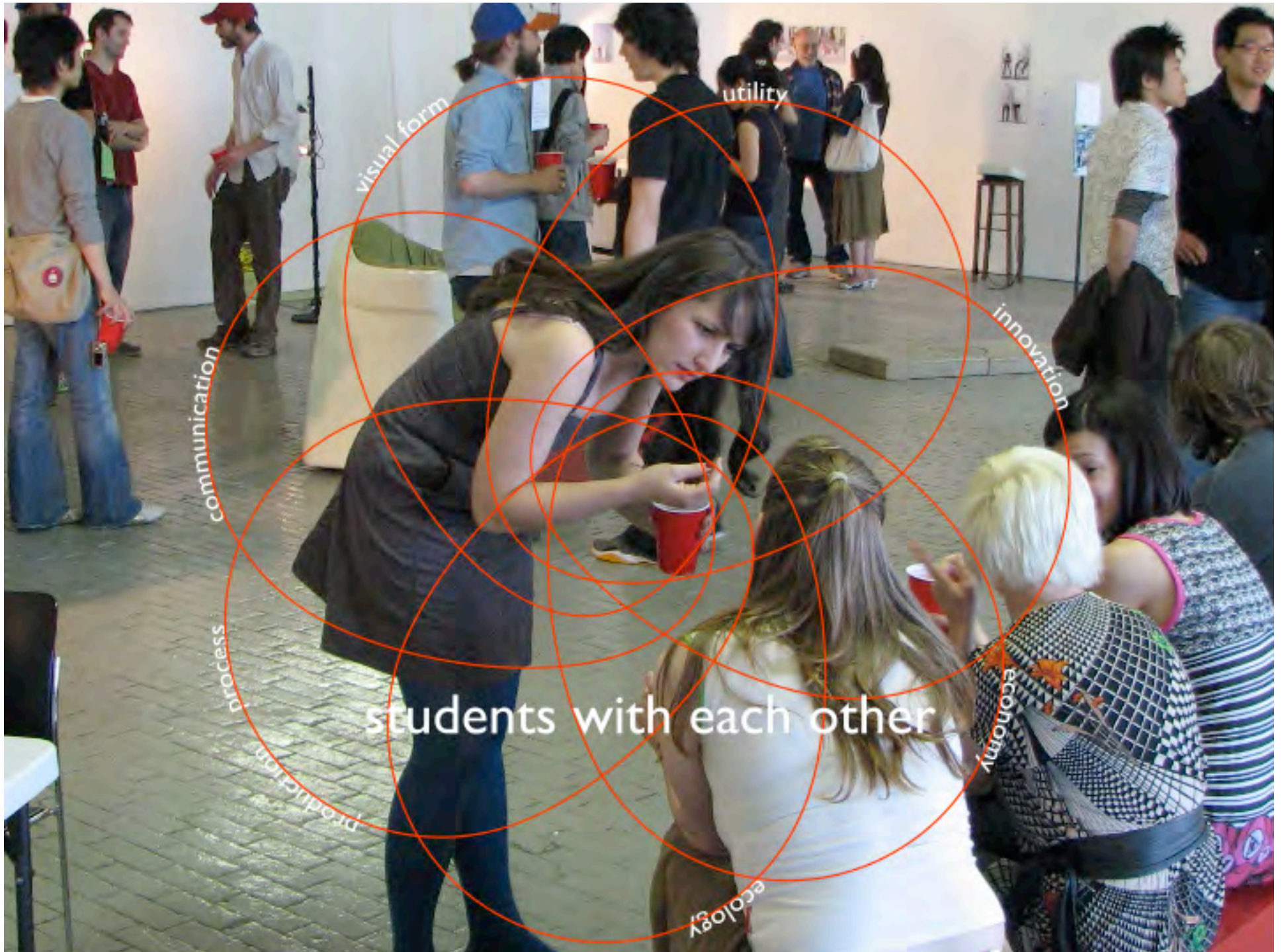

visual form

utility

innovation

communication

process

production

economy

ecology

students with each other



visual form

utility

innovation

economy

ecology

innovation

production

process

students & faculty...



visual form

utility

innovation

communication

process

production

eco

eco

students & faculty...



visual form

utility

innovation

economy

ecology

production

communication

students, faculty
& the design
community



students, faculty
& the design
community

communication

process

innovation

community



students, faculty
& the design
community

visual form

communication

process

production

ecology

economy



students, faculty
& the design
community



visual form

utility

innovation

economy

production

production

students, faculty
& the design
community

IAAhn



Pratt's
Industrial Design
in future tense ...



thanks very much ...

Matthew Burger

