



MIT Media Lab's Concept Car: with GM and Frank O. Gehry

General Motors, by developing and critically designs for a concept car. The eventual will be construction of a full-scale, running car will be hybrid powered, and drive-by-wire sufficient intelligence to know the city that it provide not just transportation, but an efficient interface to the resources that the city offers particularly concerned with innovative electronics, new materials and processes, and the for interior space, exterior form, and the experience. We will work from the beginning in a 3D geometric modeling environment (Catia) make extensive use of rapid prototyping and for producing physical scale models.

Smart Cities Group

Professor William J. Mitchell

Head, Media Arts and Sciences Program

Graduate Students:

Ryan Chin, PhD Candidate

Will Lark, MS Candidate

Phil Liang, MS Candidate

Patrik Künzler, Safdie Fellow

Raul David "Retro" Poblano, UROP

Peter Schmitt, Visiting Researcher

Susanne Seitinger, MS Candidate

MIT Media Lab

Oct 22, 2004

Collaborators:

Federico Casalegno, Visiting Scientist

David Gerber, Safdie Fellow

Mitchell Joachim, PhD Candidate

Axel Kilian, PhD Candidate

Franco Vairani, Research Scientist

Concept Car with GM and Frank O. Gehry

General Motors, by developing and critically designs for a concept car. The eventual will be construction of a full-scale, running car will be hybrid powered, and drive-by-wire sufficient intelligence to know the city that it provide not just transportation, but an efficient interface to the resources that the city offers particularly concerned with innovative electronics, new materials and processes, and the for interior space, exterior form, and the experience. We will work from the beginning in a 3D geometric modeling environment (Catia make extensive use of rapid prototyping and for producing physical scale models.

1. Motor-Wheel

Electrically powered, independently controllable **wheels** with motor, suspension, brakes, and steering contained within each wheel assembly. Placing the suspension within the wheel itself is a significant innovation, and promises some important advantages. Each wheel has only two inputs: electrical power and digital data.



Goal: Create self-contained mobile units

Concept Car with GM and Frank O. Gehry



General Motors, by developing and critically designs for a concept car. The eventual out further development and documentation of will be construction of a full-scale, running car will be hybrid powered, and drive-by-wire sufficient intelligence to know the city that it provide not just transportation, but an efficient interface to the resources that the city offers particularly concerned with innovative electrics, new materials and processes, and the for interior space, exterior form, and the experience. We will work from the beginning in a 3D geometric modeling environment (Catia) make extensive use of rapid prototyping and

2. Exoskeleton

An **exoskeleton** that connects the wheels and supports the passenger cabin, storage units, and power source. This element can be optimized for structural efficiency, and (like the frame of a sophisticated bicycle) can become a major design feature.

Goal: High level of customization



Concept Car with GM and Frank O. Gehry



General Motors, by developing and critically designs for a concept car. The eventual will be construction of a full-scale, running car will be hybrid powered, and drive-by-wire sufficient intelligence to know the city that it provide not just transportation, but an efficient interface to the resources that the city offers particularly concerned with innovative electronics, new materials and processes, and the for interior space, exterior form, and the exciting. We will work from the beginning in a

3. Drive-by-Wire

In place of traditional steering column and dashboard arrangements. This allows radical reconfiguration of the cockpit, treatment of the passenger compartment as a module that can readily be separated from the rest of the car, and creation of a multimedia driving experience that intelligently integrates data streams from a wide variety of sources and presents them to the driver and passengers in a customized, context-sensitive way.

Goal: Interior Design Freedom



Concept Car with GM and Frank O. Gehry

General Motors, by developing and critically designs for a concept car. The eventual will be construction of a full-scale, running car will be hybrid powered, and drive-by-wire sufficient intelligence to know the city that it provide not just transportation, but an efficient interface to the resources that the city offers particularly concerned with innovative electronics, new materials and processes, and the for interior space, exterior form, and the experience. We will work from the beginning in a 3D geometric modeling environment (Catia) make extensive use of rapid prototyping and for producing physical scale models.

4. No Crumple

A lightweight, technologically advanced **passenger compartment** suspended safely within the exoskeleton, like an egg protected within an egg carton. This compartment need not be fabricated from sheetmetal and glass. It can exploit the possibilities of advanced materials and embedded electronics to provide high levels of visibility, safety, climate control, lighting, sensing capability, and interior displays. And it provides an opportunity to break away from the familiar automobile aesthetic of painted sheetmetal

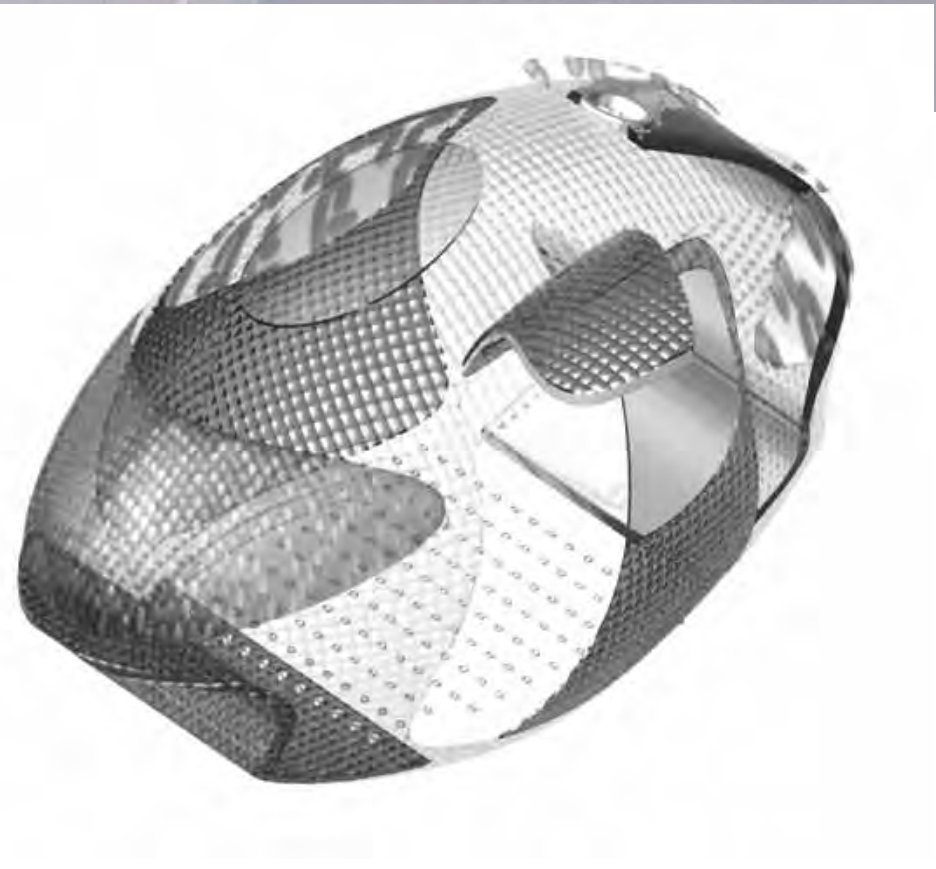

Concept Car with GM and Frank O. Gehry

General Motors, by developing and critically designs for a concept car. The eventual further development and documentation of will be construction of a full-scale, running car will be hybrid powered, and drive-by-wire sufficient intelligence to know the city that it provide not just transportation, but an efficient interface to the resources that the city offers particularly concerned with innovative electronics, new materials and processes, and the for interior space, exterior form, and the experience. We will work from the beginning in a 3D geometric modeling environment (Catia) make extensive use of rapid prototyping and for producing physical scale models.

5. Hold Safely

Go beyond seatbelts and airbags. Think of the passenger seat, from the beginning, as a gentle robot that knows how to hold you safely and comfortably under any conditions that may be encountered.

Goal: zero passenger deaths.



quick review in- wheel suspension

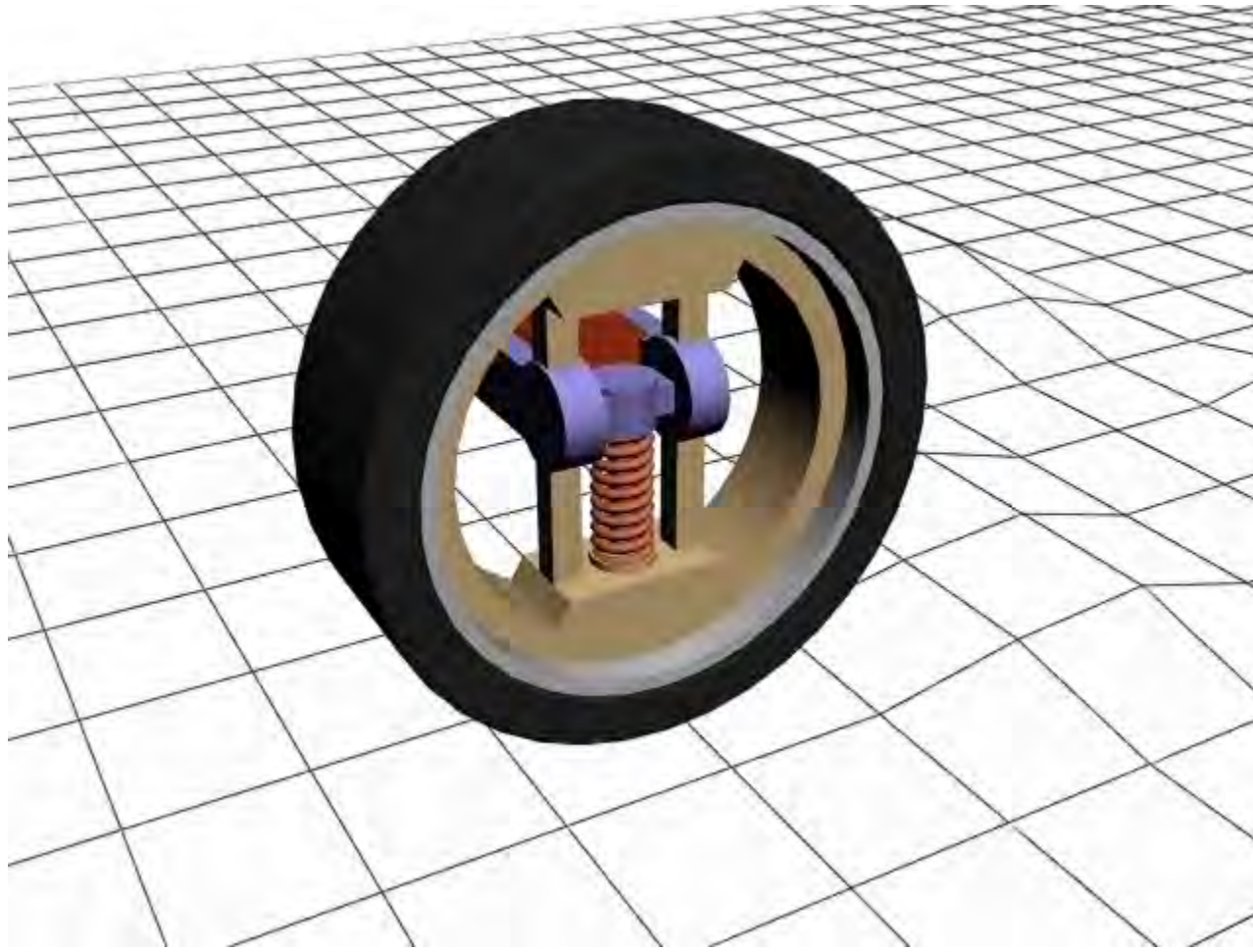

quick review in- wheel suspension

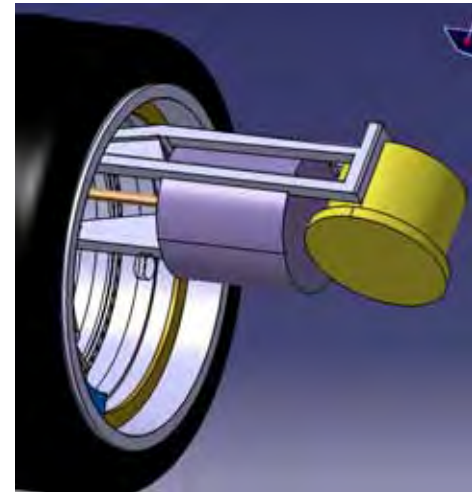
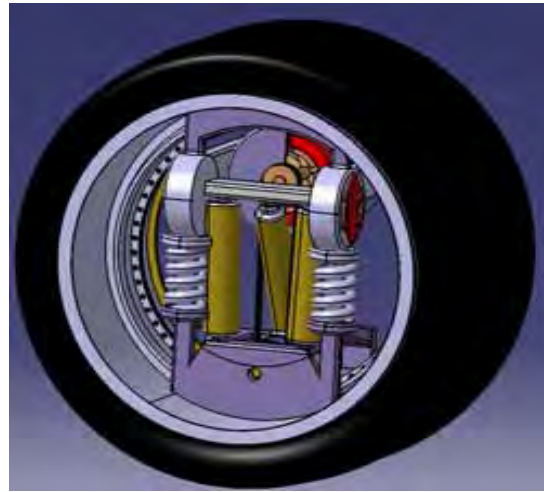
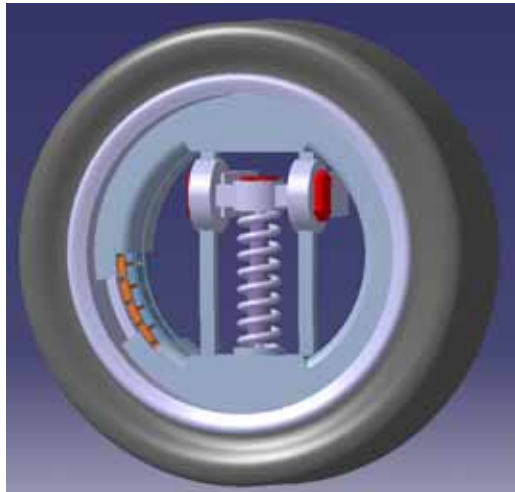

running prototype #1- a summer's work



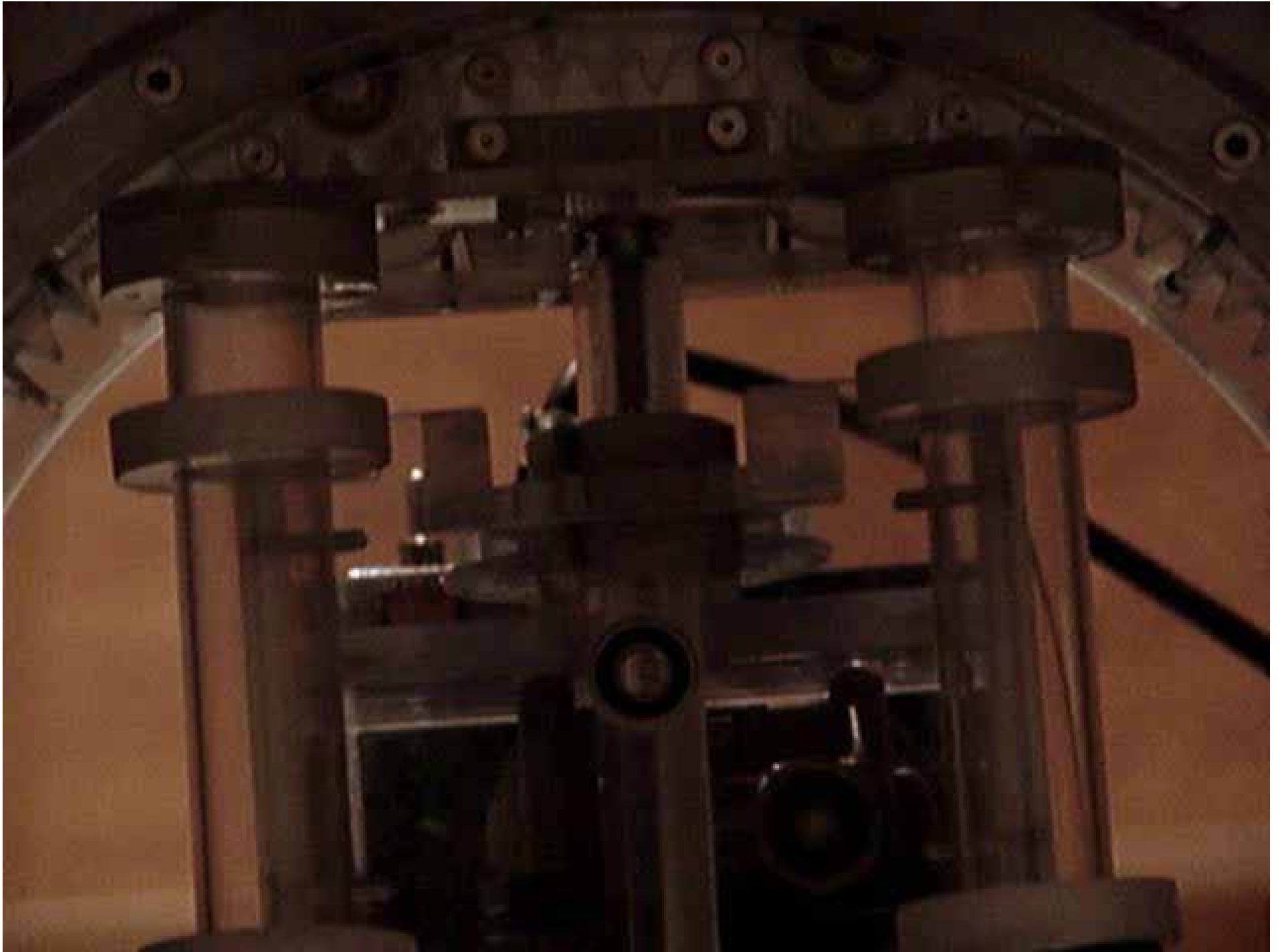

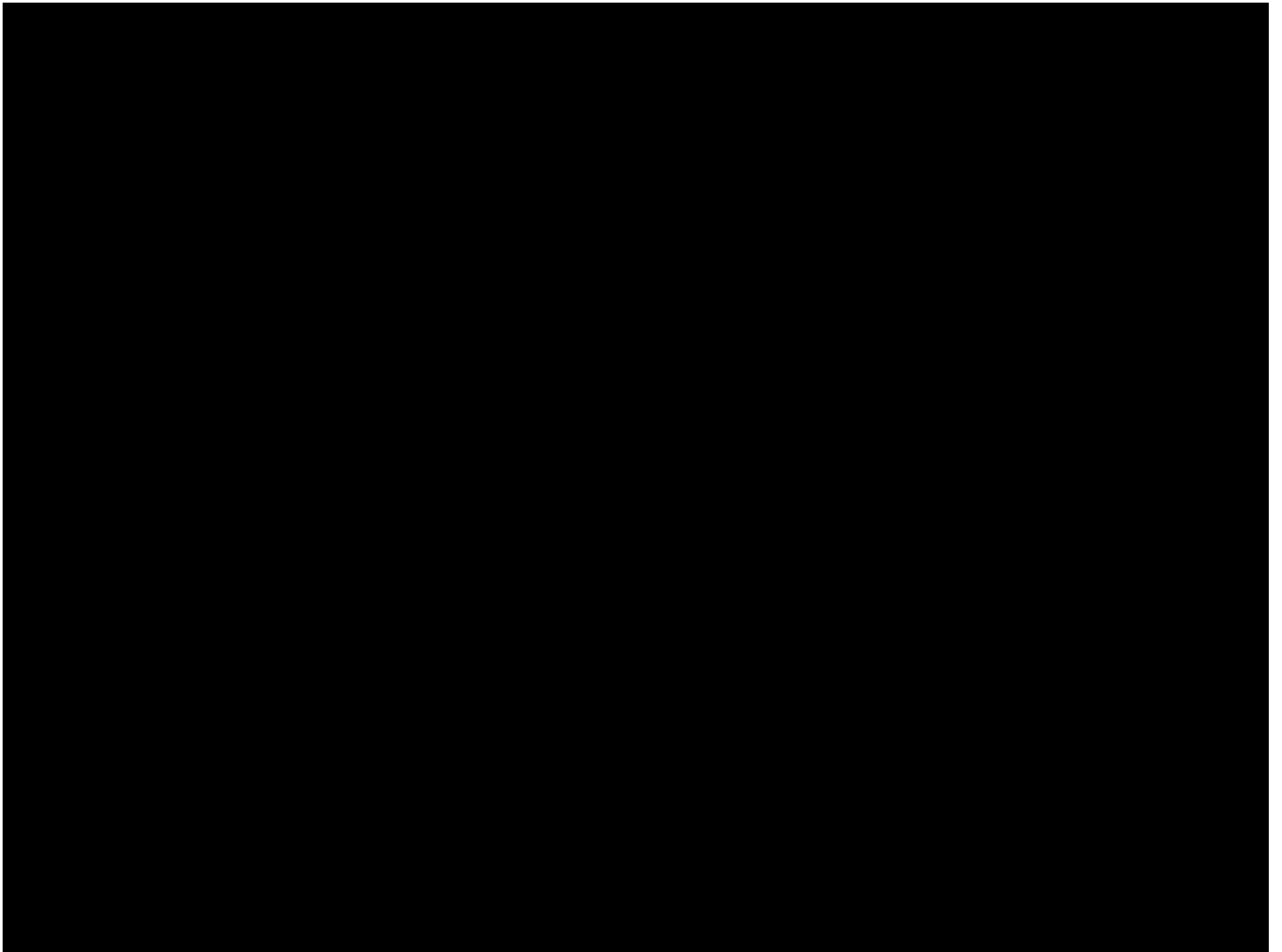



SOFT_Car

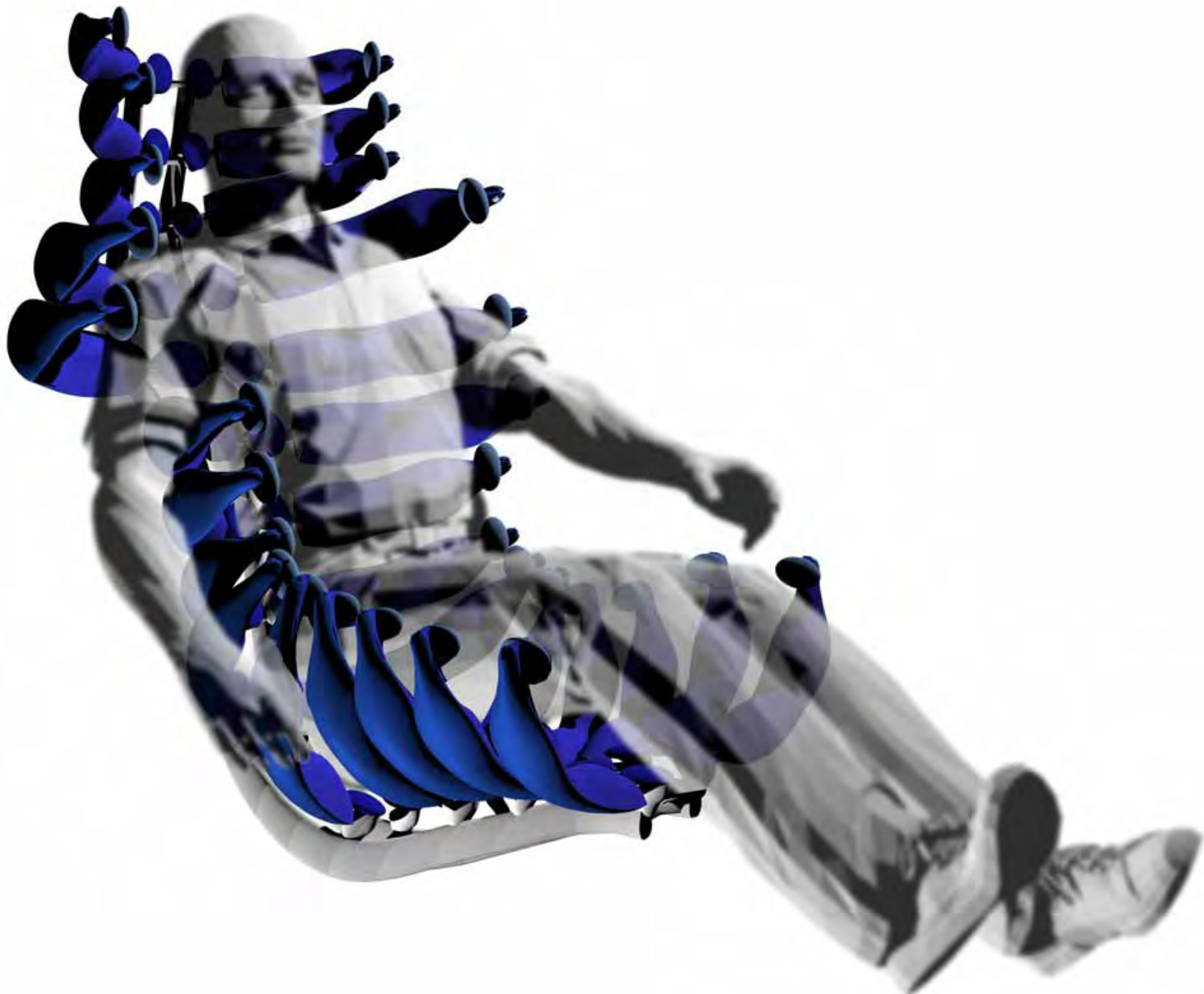



CAR_SOFT

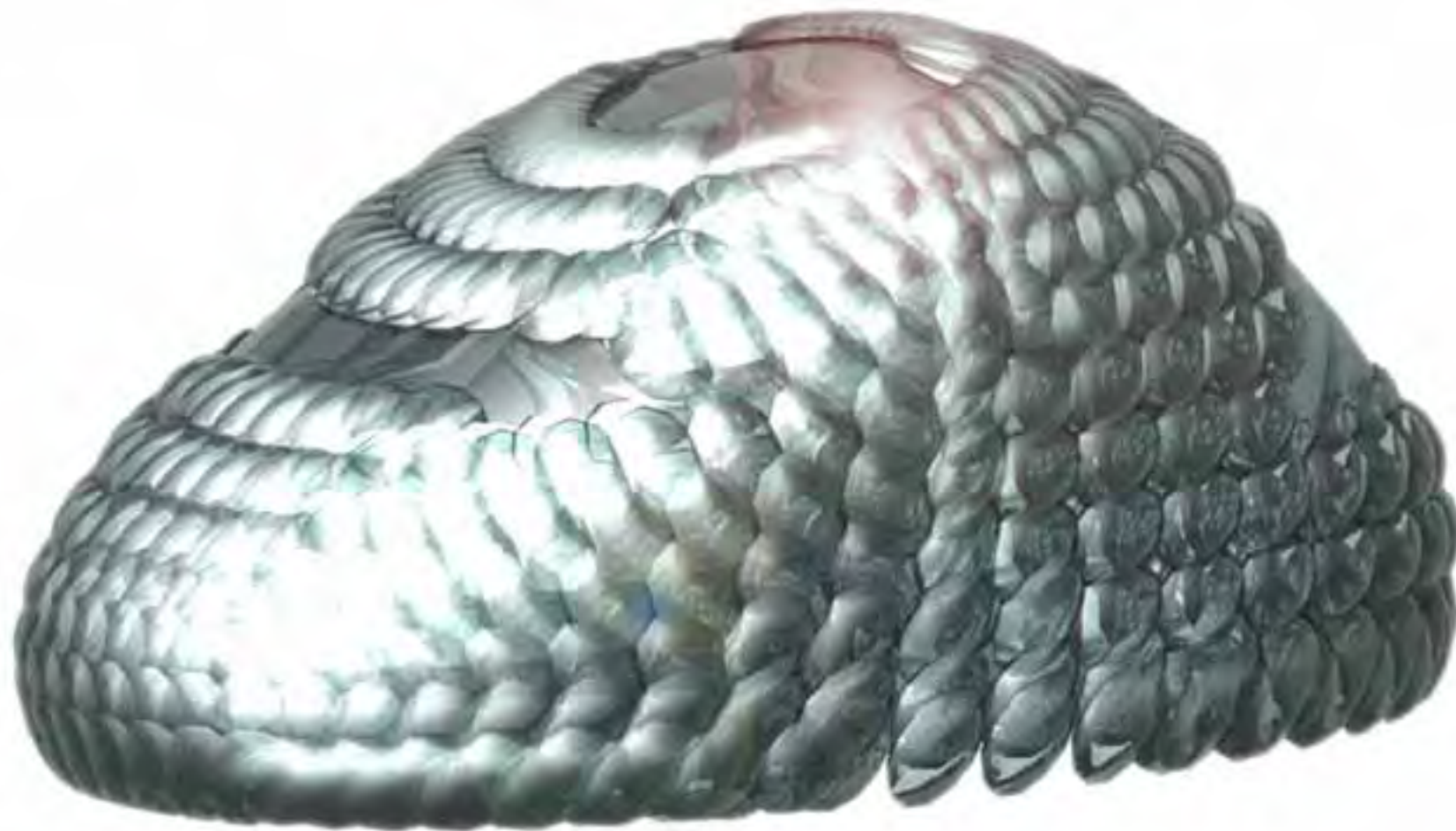

CAR_SOFT

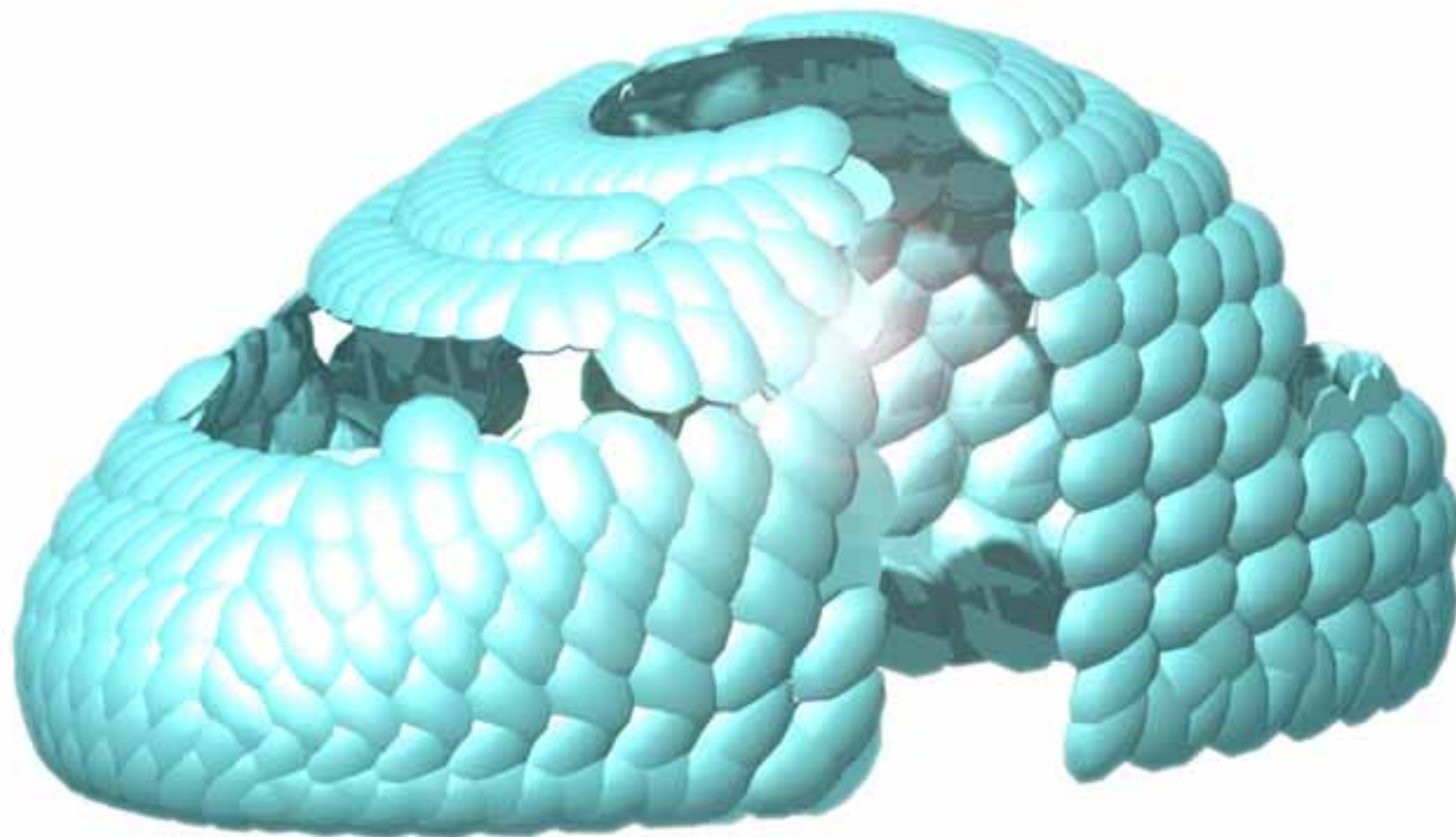

The Blahnik

/ Axel Kilian

Material Spring
Side Ingress/Egress
Front arms – Dynamic Cabin

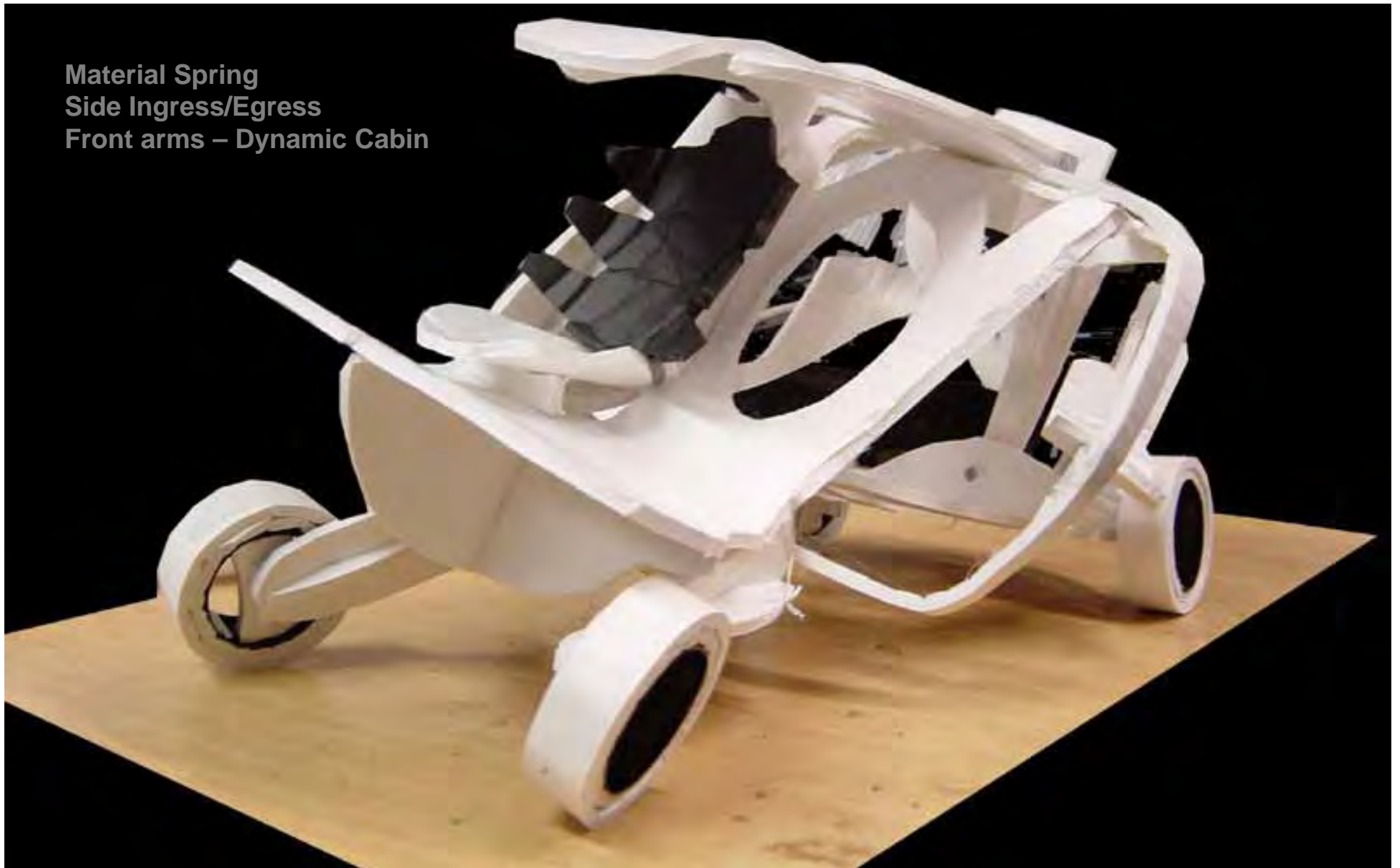

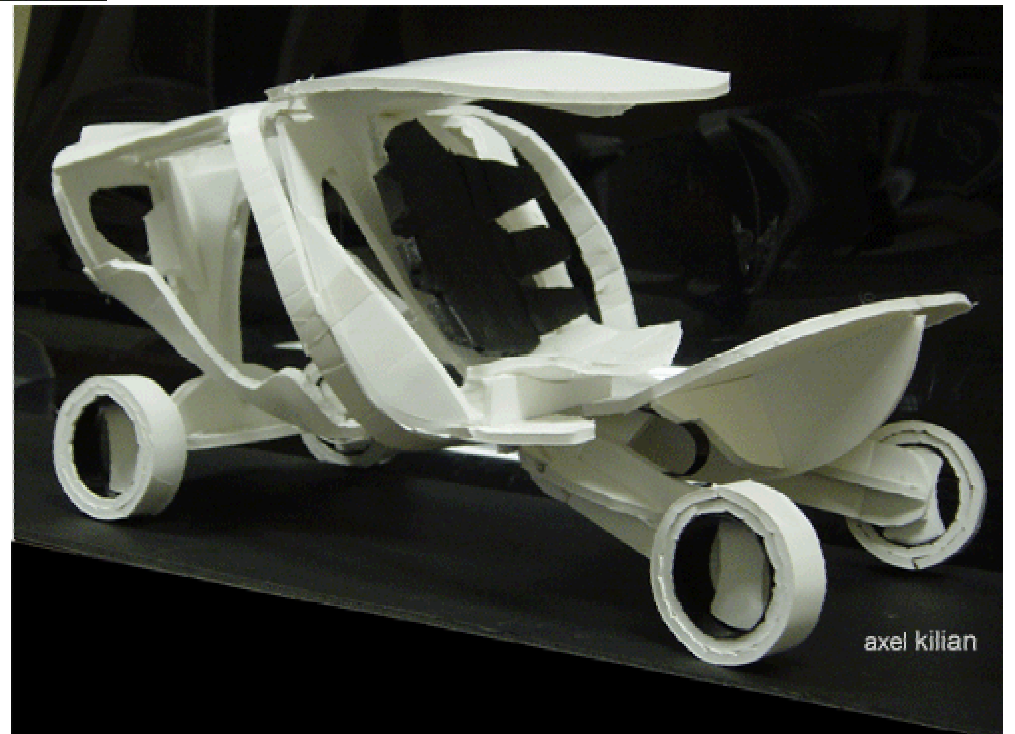
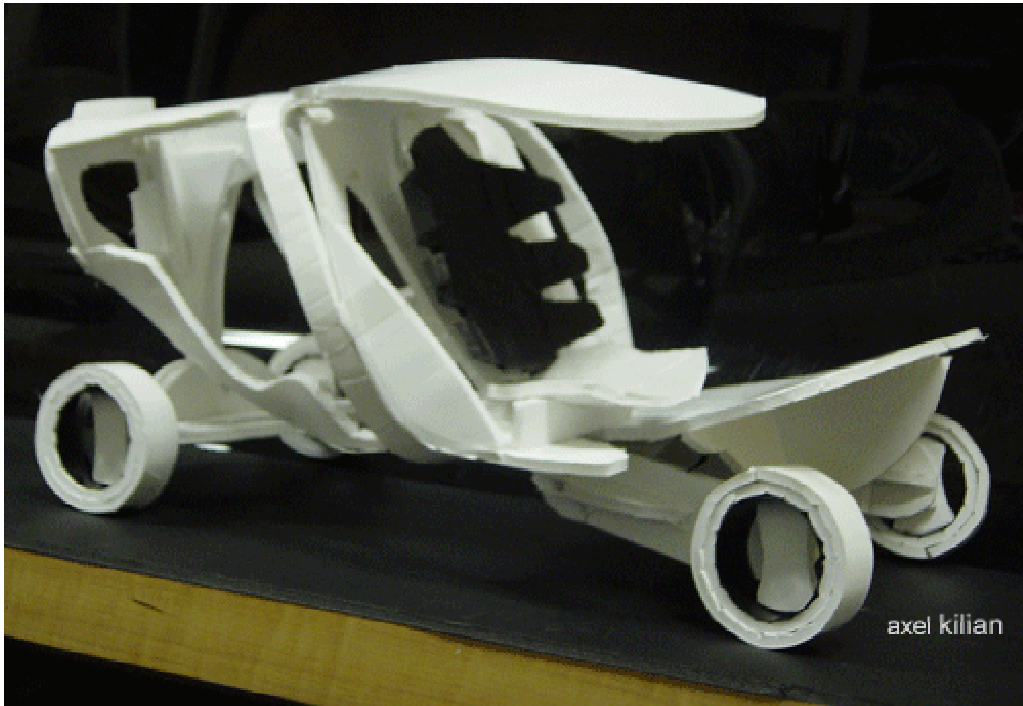

The Basket case / Will Lark

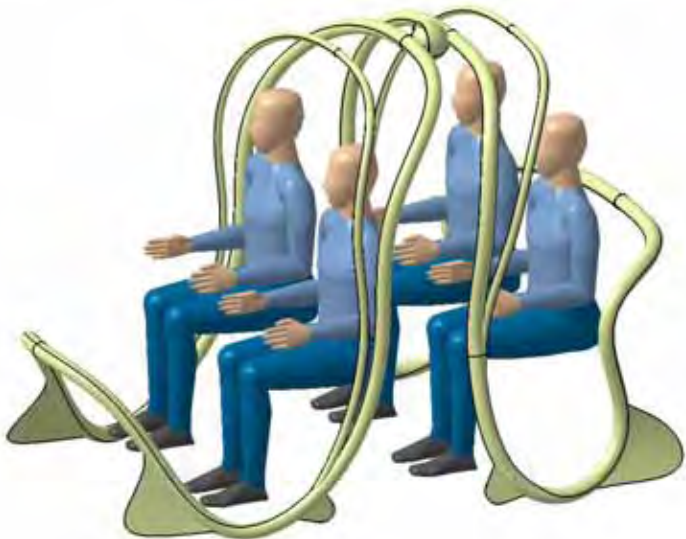
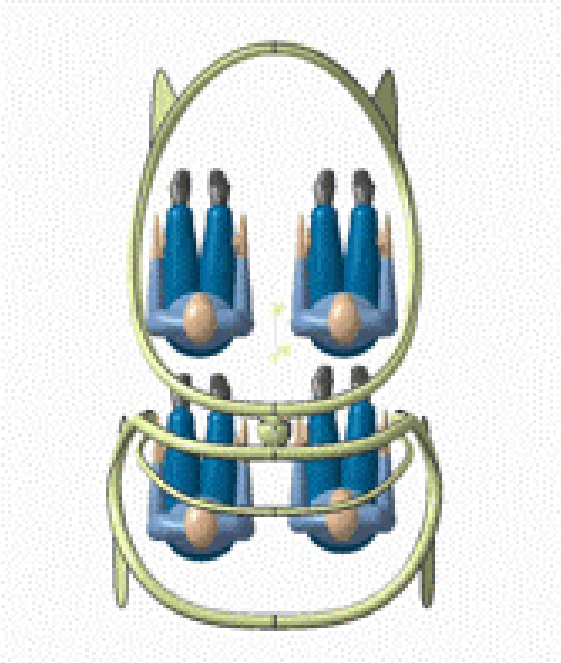
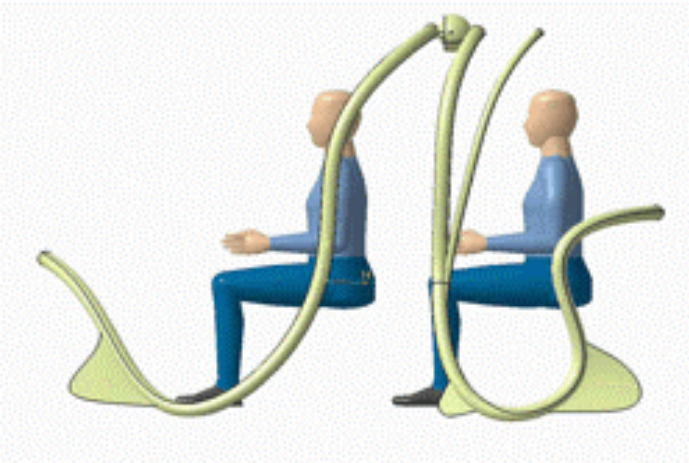

Dampening material placed between frame
Side & front Ingress/Egress
Twisting & Rocking frame – Dynamic Cabin



The Basket case / Will Lark



The Gator

/ Will Lark

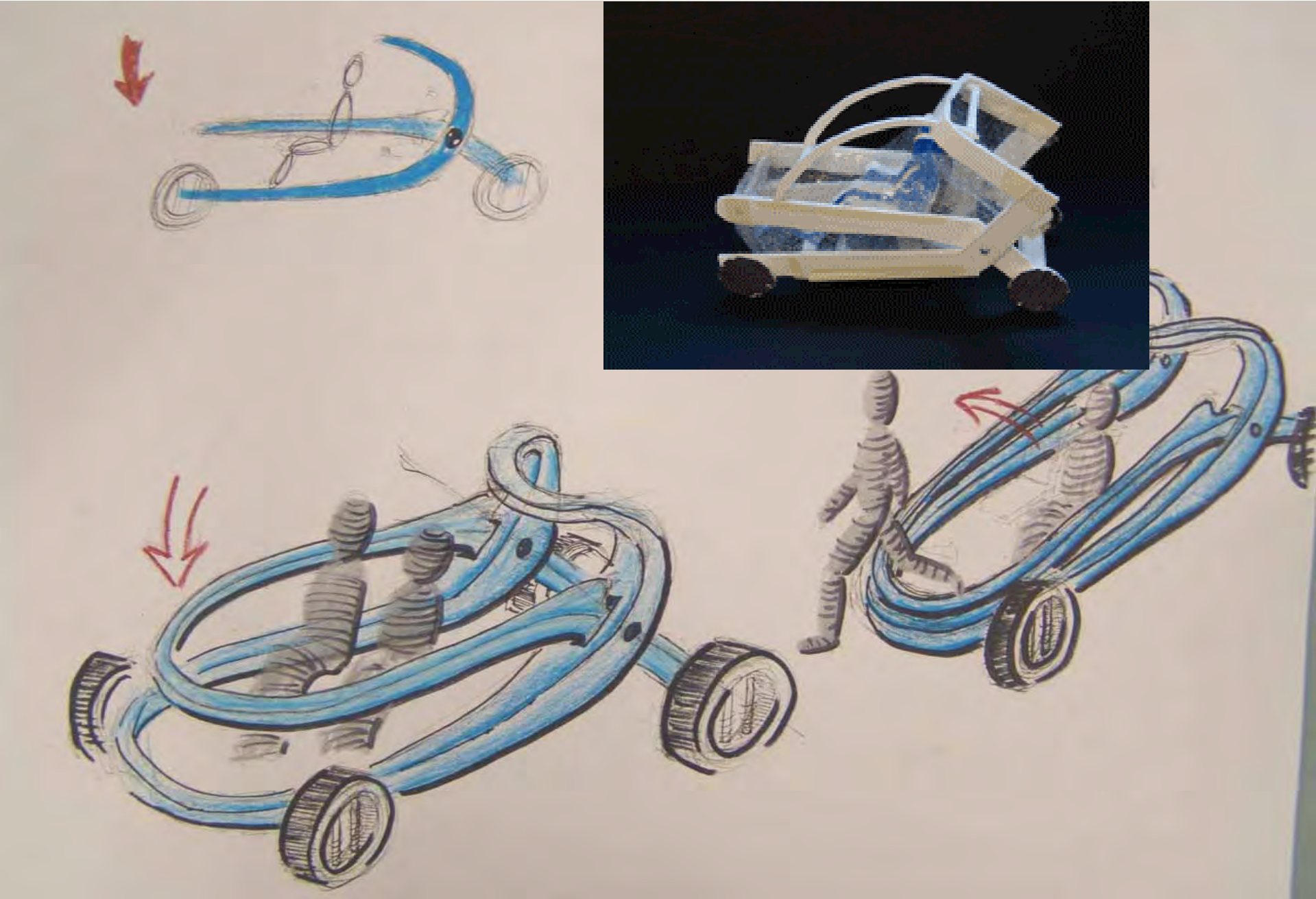













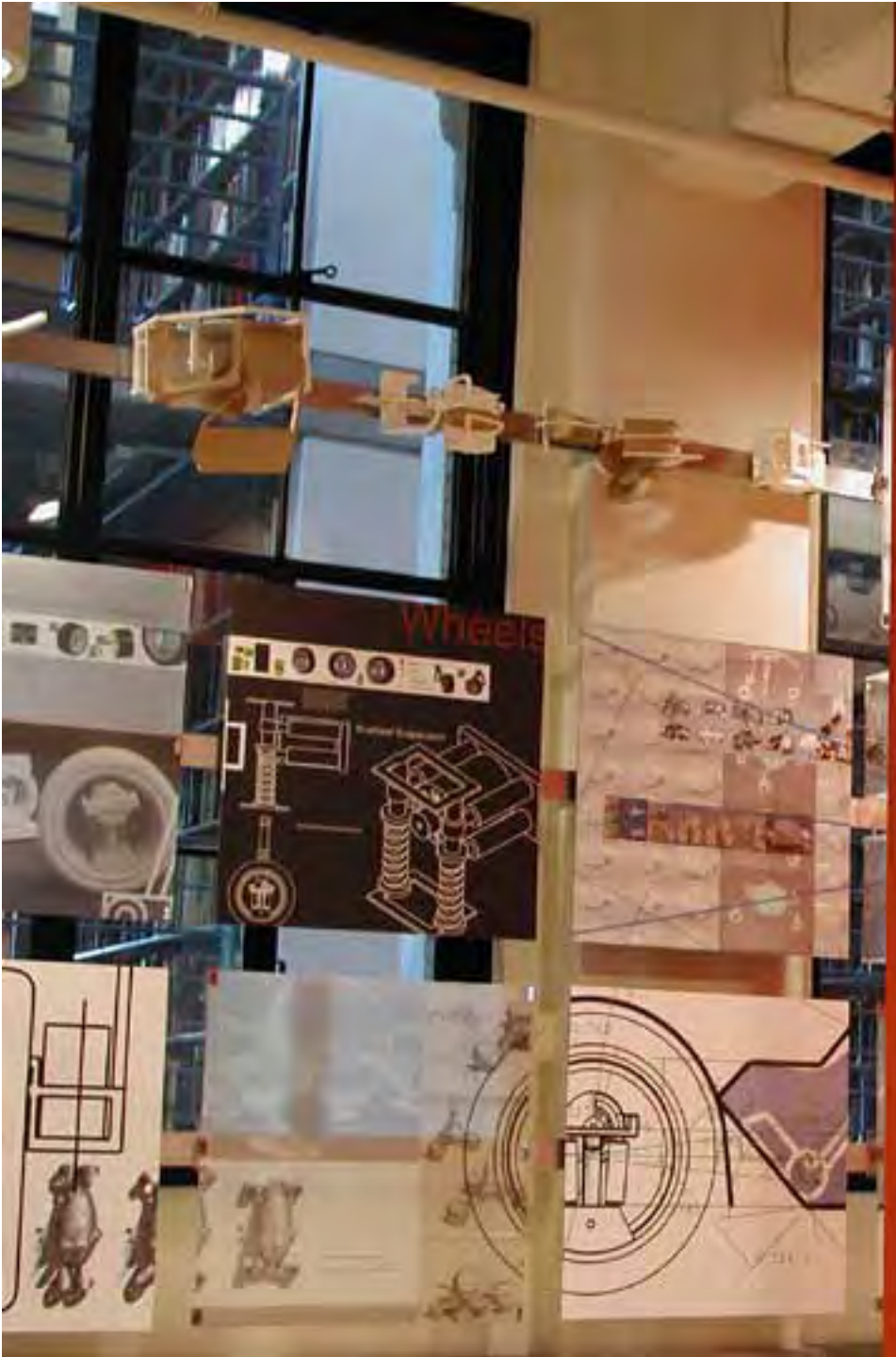



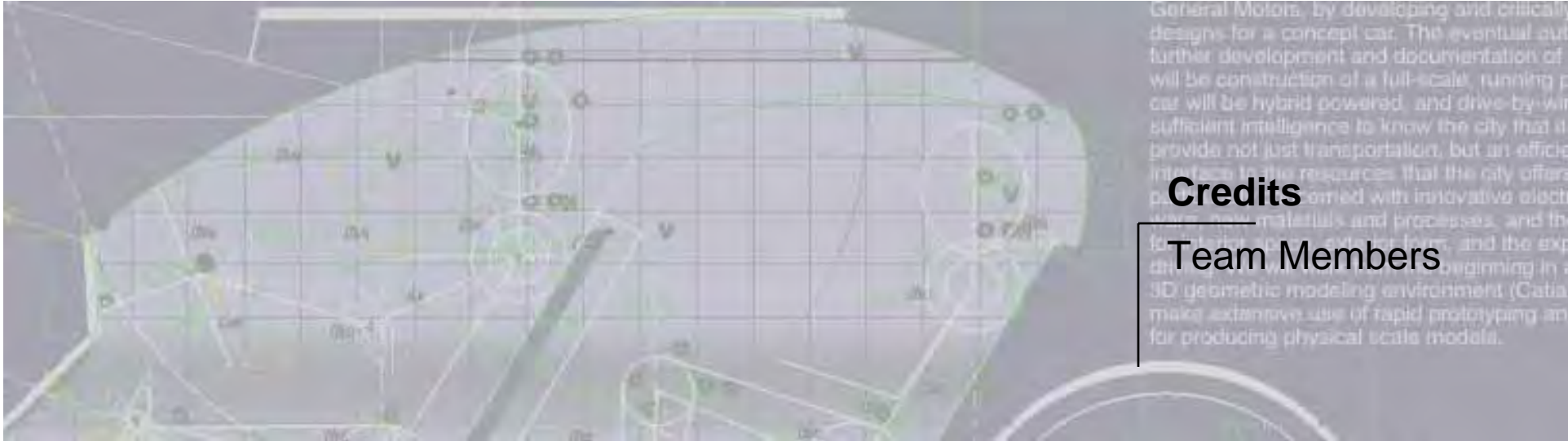

Credits

Team Members

Instructors

William J. Mitchell
James Glymph
Frank O. Gehry

Studio Coordinator

Ryan Chin

Course Administrator

Betty Lou McClanahan

Course Collaborators

James Gips
Axel Kilian
Franco Vairani
Steven Smith

Collaborative Research

Federico Casalegno
Han Hoang
Nikki Pfarr

Students

Robyn Allen
Louis Basel
Marcel Botha
Luis Berrios-Negron
Darren Chang
Brian Chan
Chad Dyner
Victor Gane
David Gerber
Jonathan Gips
Joshua Goldwitz
Ziga Ivanic

Mitchell Joachim
Sotirios Kotsopoulos
Patrik Künzler
Ashwani Kumar
Will Lark
Philip Liang
Yanni Loukissas
Anmol Madan
Raul-David Poblano
Olumuyiwa Oni

Christianna Raber
Andres Sevtsuk
Peter Schmitt
David Spectre
Maya Turre
Conor Walsh
Tiffany Yang
Giampaolo Zen